



# MAX 10 Clocking and PLL User Guide

***UG-M10CLKPLL***  
***2017.02.21***

Last updated for Quartus Prime Design Suite: 16.0

 [Subscribe](#)

 [Send Feedback](#)



## Contents

---

<b>1 MAX<sup>®</sup> 10 Clocking and PLL Overview</b> .....	<b>4</b>
1.1 Clock Networks Overview.....	4
1.2 Internal Oscillator Overview.....	4
1.3 PLLs Overview.....	4
<b>2 MAX 10 Clocking and PLL Architecture and Features</b> .....	<b>5</b>
2.1 Clock Networks Architecture and Features.....	5
2.1.1 Global Clock Networks.....	5
2.1.2 Clock Pins Introduction.....	5
2.1.3 Clock Resources.....	6
2.1.4 Global Clock Network Sources.....	6
2.1.5 Global Clock Control Block.....	8
2.1.6 Global Clock Network Power Down.....	10
2.1.7 Clock Enable Signals.....	11
2.2 Internal Oscillator Architecture and Features.....	12
2.3 PLLs Architecture and Features.....	12
2.3.1 PLL Architecture.....	12
2.3.2 PLL Features.....	13
2.3.3 PLL Locations.....	14
2.3.4 Clock Pin to PLL Connections.....	16
2.3.5 PLL Counter to GCLK Connections.....	16
2.3.6 PLL Control Signals.....	17
2.3.7 Clock Feedback Modes.....	18
2.3.8 PLL External Clock Output.....	22
2.3.9 ADC Clock Input from PLL.....	23
2.3.10 Spread-Spectrum Clocking.....	23
2.3.11 PLL Programmable Parameters.....	23
2.3.12 Clock Switchover.....	26
2.3.13 PLL Cascading.....	30
2.3.14 PLL Reconfiguration.....	31
<b>3 MAX 10 Clocking and PLL Design Considerations</b> .....	<b>33</b>
3.1 Clock Networks Design Considerations.....	33
3.1.1 Guideline: Clock Enable Signals.....	33
3.1.2 Guideline: Connectivity Restrictions.....	33
3.2 Internal Oscillator Design Considerations.....	33
3.2.1 Guideline: Connectivity Restrictions.....	33
3.3 PLLs Design Considerations.....	34
3.3.1 Guideline: PLL Control Signals.....	34
3.3.2 Guideline: Connectivity Restrictions.....	34
3.3.3 Guideline: Self-Reset.....	34
3.3.4 Guideline: Output Clocks.....	35
3.3.5 Guideline: PLL Cascading.....	35
3.3.6 Guideline: Clock Switchover.....	35
3.3.7 Guideline: .mif Streaming in PLL Reconfiguration.....	37
3.3.8 Guideline: scandone Signal for PLL Reconfiguration.....	37



<b>4 MAX 10 Clocking and PLL Implementation Guides.....</b>	<b>38</b>
4.1 ALTCLKCTRL IP Core.....	38
4.2 ALTPLL IP Core.....	38
4.2.1 Expanding the PLL Lock Range.....	39
4.2.2 Programmable Bandwidth with Advanced Parameters.....	40
4.2.3 PLL Dynamic Reconfiguration Implementation.....	41
4.2.4 Dynamic Phase Configuration Implementation.....	45
4.3 ALTPLL_RECONFIG IP Core.....	47
4.3.1 Obtaining the Resource Utilization Report.....	48
4.4 Internal Oscillator IP Core.....	48
<b>5 ALTCLKCTRL IP Core References.....</b>	<b>50</b>
5.1 ALTCLKCTRL Parameters.....	50
5.2 ALTCLKCTRL Ports and Signals.....	51
<b>6 ALTPLL IP Core References.....</b>	<b>52</b>
6.1 ALTPLL Parameters.....	52
6.1.1 Operation Modes Parameter Settings.....	52
6.1.2 PLL Control Signals Parameter Settings.....	52
6.1.3 Programmable Bandwidth Parameter Settings.....	53
6.1.4 Clock Switchover Parameter Settings.....	53
6.1.5 PLL Dynamic Reconfiguration Parameter Settings.....	54
6.1.6 Dynamic Phase Configuration Parameter Settings.....	54
6.1.7 Output Clocks Parameter Settings.....	55
6.2 ALTPLL Ports and Signals.....	56
<b>7 ALTPLL_RECONFIG IP Core References.....</b>	<b>59</b>
7.1 ALTPLL_RECONFIG Parameters.....	59
7.2 ALTPLL_RECONFIG Ports and Signals.....	60
7.3 ALTPLL_RECONFIG Counter Settings.....	62
<b>8 Internal Oscillator IP Core References.....</b>	<b>65</b>
8.1 Internal Oscillator Parameters.....	65
8.2 Internal Oscillator Ports and Signals.....	65
<b>A MAX 10 Clocking and PLL User Guide Archives.....</b>	<b>66</b>
<b>B Document Revision History for MAX 10 Clocking and PLL User Guide.....</b>	<b>67</b>



## 1 MAX<sup>®</sup> 10 Clocking and PLL Overview

---

### 1.1 Clock Networks Overview

MAX<sup>®</sup> 10 devices support global clock (GCLK) networks.

Clock networks provide clock sources for the core. You can use clock networks in high fan-out global signal network such as reset and clear.

### 1.2 Internal Oscillator Overview

MAX 10 devices offer built-in internal oscillator up to 116 MHz.

You can enable or disable the internal oscillator.

### 1.3 PLLs Overview

Phase-locked loops (PLLs) provide robust clock management and synthesis for device clock management, external system clock management, and I/O interface clocking.

You can use the PLLs as follows:

- Zero-delay buffer
- Jitter attenuator
- Low-skew fan-out buffer
- Frequency synthesizer
- Reduce the number of oscillators required on the board
- Reduce the clock pins used in the device by synthesizing multiple clock frequencies from a single reference clock source
- On-chip clock de-skew
- Dynamic phase shift
- Counters reconfiguration
- Bandwidth reconfiguration
- Programmable output duty cycle
- PLL cascading
- Reference clock switchover
- Drive the analog-to-digital converter (ADC) clock



## 2 MAX 10 Clocking and PLL Architecture and Features

---

### 2.1 Clock Networks Architecture and Features

#### 2.1.1 Global Clock Networks

GCLKs drive throughout the entire device, feeding all device quadrants. All resources in the device, such as the I/O elements, logic array blocks (LABs), dedicated multiplier blocks, and M9K memory blocks can use GCLKs as clock sources. Use these clock network resources for control signals, such as clock enables and clears fed by an external pin. Internal logic can also drive GCLKs for internally-generated GCLKs and asynchronous clears, clock enables, or other control signals with high fan-out.

#### 2.1.2 Clock Pins Introduction

There are two types of external clock pins that can drive the GCLK networks.

##### Dedicated Clock Input Pins

You can use the dedicated clock input pins ( $CLK\langle\#\rangle[p,n]$ ) to drive clock and global signals, such as asynchronous clears, presets, and clock enables for GCLK networks.

If you do not use the dedicated clock input pins for clock input, you can also use them as general-purpose input or output pins.

The  $CLK$  pins can be single-ended or differential inputs. When you use the  $CLK$  pins as single-ended clock inputs, both the  $CLK\langle\#\rangle p$  and  $CLK\langle\#\rangle n$  pins have dedicated connection to the GCLK networks. When you use the  $CLK$  pins as differential inputs, pair two clock pins of the same number to receive differential signaling.

##### Dual-Purpose Clock Pins

You can use the dual-purpose clock (DPCLK) pins for high fan-out control signals, such as protocol signals, TRDY and IRDY signals for PCI via GCLK networks.

The DPCLK pins are only available on the left and right of the I/O banks.



### 2.1.3 Clock Resources

**Table 1. MAX 10 Clock Resources**

Clock Resource	Device	Number of Resources Available	Source of Clock Resource
Dedicated clock input pins	<ul style="list-style-type: none"> <li>• 10M02</li> <li>• 10M04</li> <li>• 10M08</li> </ul>	8 single-ended or 4 differential	CLK[3..0][p,n] pins on the left and right of the I/O banks
	<ul style="list-style-type: none"> <li>• 10M16</li> <li>• 10M25</li> <li>• 10M40</li> <li>• 10M50</li> </ul>	16 single-ended or 8 differential	CLK[7..0][p,n] pins on the top, left, bottom, and right of the I/O banks
DPCLK pins	All	4	DPCLK[3..0] pins on the left and right of the I/O banks

For more information about the clock input pins connections, refer to the pin connection guidelines.

**Related Links**

[MAX 10 FPGA Device Family Pin Connection Guidelines](#)

### 2.1.4 Global Clock Network Sources

**Table 2. MAX 10 Clock Pins Connectivity to the GCLK Networks**

CLK Pin	GCLK
CLK0p	GCLK[0,2,4]
CLK0n	GCLK[1,2]
CLK1p	GCLK[1,3,4]
CLK1n	GCLK[0,3]
CLK2p	GCLK[5,7,9]
CLK2n	GCLK[6,7]
CLK3p	GCLK[6,8,9]
CLK3n	GCLK[5,8]
CLK4p <sup>1</sup>	GCLK[10,12,14]
CLK4n <sup>1</sup>	GCLK[11,12]
CLK5p <sup>1</sup>	GCLK[11,13,14]
CLK5n <sup>1</sup>	GCLK[10,13]
CLK6p <sup>1</sup>	GCLK[15,17,19]
CLK6n <sup>1</sup>	GCLK[16,17]

*continued...*

1 This only applies to 10M16, 10M25, 10M40, and 10M50 devices.



CLK Pin	GCLK
CLK7p <sup>1</sup>	GCLK[16,18,19]
CLK7n <sup>1</sup>	GCLK[15,18]
DPCLK0	GCLK[0,2]
DPCLK1	GCLK[1,3,4]
DPCLK2	GCLK[5,7]
DPCLK3	GCLK[6,8,9]

Figure 1. GCLK Network Sources for 10M02, 10M04, and 10M08 Devices

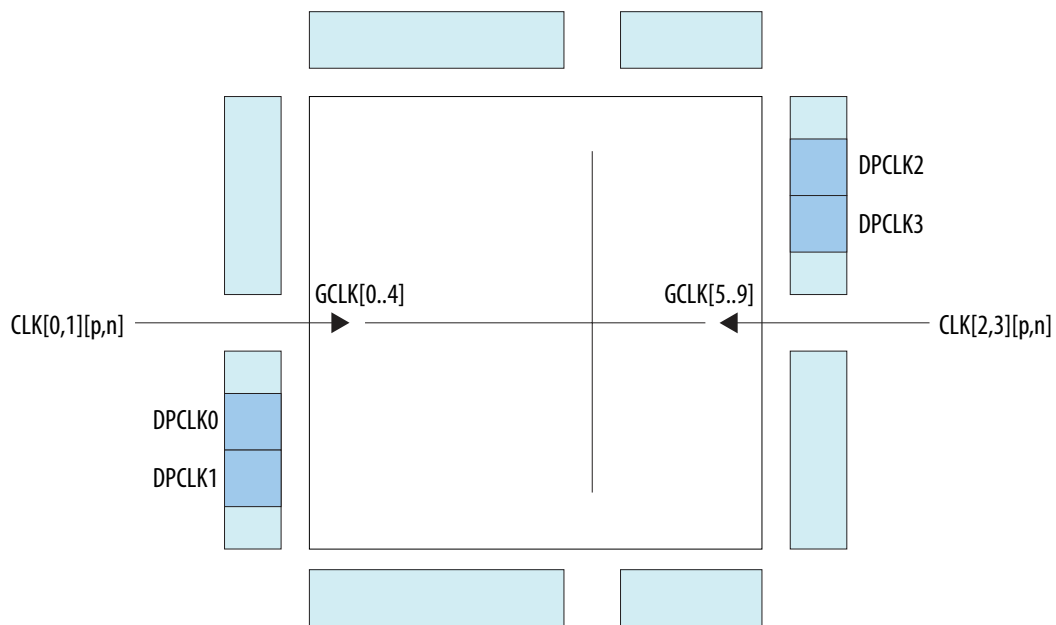
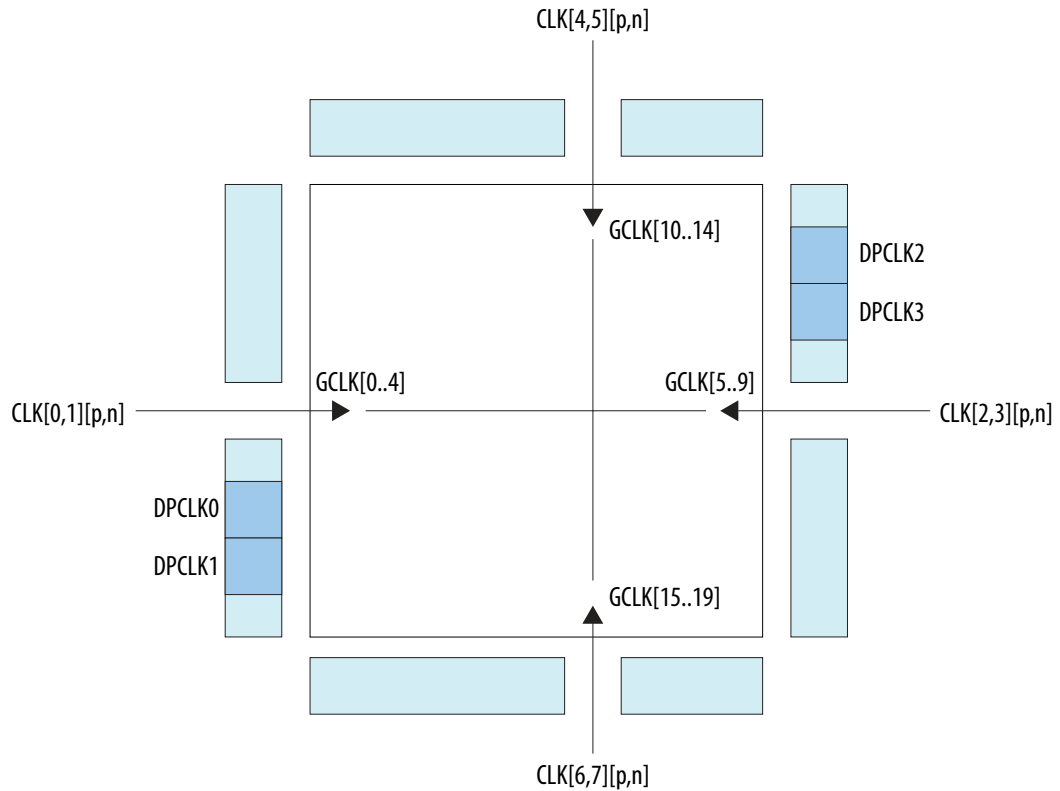

Figure 2. GCLK Network Sources for 10M16, 10M25, 10M40, and 10M50 Devices



### 2.1.5 Global Clock Control Block

The clock control block drives GCLKs. The clock control blocks are located on each side of the device, close to the dedicated clock input pins. GCLKs are optimized for minimum clock skew and delay.

The clock control block has the following functions:

- Dynamic GCLK clock source selection (not applicable for DPCLK pins and internal logic input)
- GCLK multiplexing
- GCLK network power down (dynamic enable and disable)

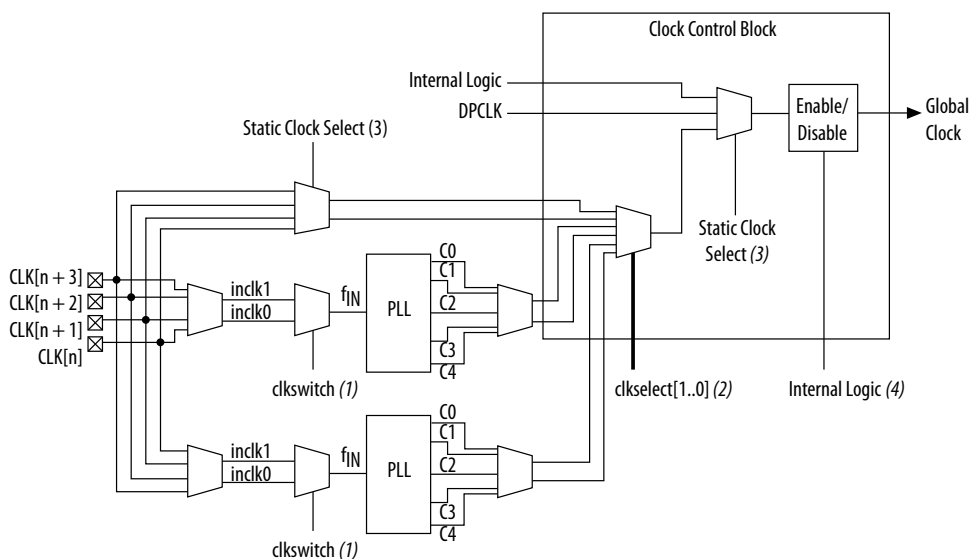



**Table 3. Clock Control Block Inputs**

Input	Description
Dedicated clock input pins	Dedicated clock input pins can drive clocks or global signals, such as synchronous and asynchronous clears, presets, or clock enables onto given GCLKs.
DPCLK pins	DPCLK pins are bidirectional dual function pins that are used for high fan-out control signals, such as protocol signals, TRDY and IRDY signals for PCI via the GCLK. Clock control blocks that have inputs driven by DPCLK pins cannot drive PLL inputs.
PLL counter outputs	PLL counter outputs can drive the GCLK.
Internal logic	You can drive the GCLK through logic array routing to enable the internal logic elements (LEs) to drive a high fan-out, low-skew signal path. Clock control blocks that have inputs driven by internal logic cannot drive PLL inputs.

**Figure 3. Clock Control Block**



**Notes:**

- (1) The clkswitch signal can either be set through the configuration file or dynamically set when using the manual PLL switchover feature. The output of the multiplexer is the input clock (fIN) for the PLL.
- (2) The clkselect[1..0] signals are fed by internal logic. You can use the clkselect[1..0] signals to dynamically select the clock source for the GCLK when the device is in user mode. Only one PLL (applicable to PLLs on the same side) can be selected as the clock source to the GCLK.
- (3) The static clock select signals are set in the configuration file. Therefore, dynamic control when the device is in user mode is not feasible.
- (4) You can use internal logic to enable or disable the GCLK in user mode.

Each MAX 10 device has a maximum of 20 clock control blocks. There are five clock control blocks on each side of the device.

Each PLL generates five clock outputs through the c[4..0] counters. Two of these clocks can drive the GCLK through a clock control block.

From the Clock Control Block Inputs table, only the following inputs can drive into any given clock control block:

- Two dedicated clock input pins
- Two PLL counter outputs
- One DPCLK pin
- One source from internal logic

The output from the clock control block in turn feeds the corresponding GCLK. The GCLK can drive the PLL input if the clock control block inputs are outputs of another PLL or dedicated clock input pins. Normal I/O pins cannot drive the PLL input clock port.

**Figure 4. Clock Control Block on Each Side of the Device**

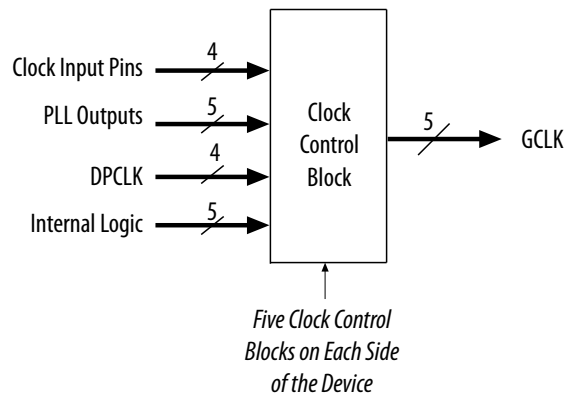

Out of these five inputs to any clock control block, the two clock input pins and two PLL outputs are dynamically selected to feed a GCLK. The clock control block supports static selection of the signal from internal logic.

**Related Links**

- [ALTCLKCTRL Parameters](#) on page 50
- [ALTCLKCTRL Ports and Signals](#) on page 51

**2.1.6 Global Clock Network Power Down**

You can disable the MAX 10 GCLK (power down) by using both static and dynamic approaches. In the static approach, configuration bits are set in the configuration file generated by the Quartus® Prime software, which automatically disables unused GCLKs. The dynamic clock enable or disable feature allows internal logic to control clock enable or disable of the GCLKs.

When a clock network is disabled, all the logic fed by the clock network is in an off-state, reducing the overall power consumption of the device. This function is independent of the PLL and is applied directly on the clock network.

You can set the input clock sources and the `clkena` signals for the GCLK multiplexers through the ALTCLKCTRL IP core parameter editor in the Quartus Prime software.

**Related Links**

- [ALTCLKCTRL Parameters](#) on page 50
- [ALTCLKCTRL Ports and Signals](#) on page 51

## 2.1.7 Clock Enable Signals

The MAX 10 devices support `clkena` signals at the GCLK network level. This allows you to gate off the clock even when a PLL is used. After reenabling the output clock, the PLL does not need a resynchronization or relock period because the circuit gates off the clock at the clock network level. In addition, the PLL can remain locked independent of the `clkena` signals because the loop-related counters are not affected.

**Figure 5. clkena Implementation**

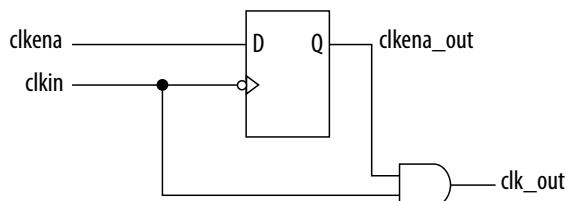

*Note:* The `clkena` circuitry controlling the C0 output of the PLL to an output pin is implemented with two registers instead of a single register.

**Figure 6. Example Waveform of clkena Implementation with Output Enable**

The `clkena` signal is sampled on the falling edge of the clock (`clkina`). This feature is useful for applications that require low power or sleep mode.

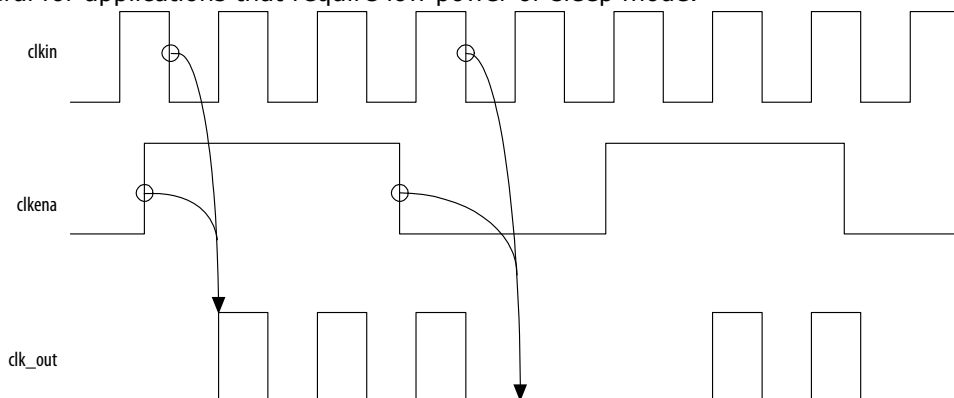

The `clkena` signal can also disable clock outputs if the system is not tolerant to frequency overshoot during PLL resynchronization.

### Related Links

- [Guideline: Clock Enable Signals](#) on page 33
- [ALTCLKCTRL Parameters](#) on page 50
- [ALTCLKCTRL Ports and Signals](#) on page 51

## 2.2 Internal Oscillator Architecture and Features

MAX 10 devices have built-in internal ring oscillator with clock multiplexers and dividers. The internal ring oscillator operates up to 232 MHz which is not accessible. This operating frequency further divides down to slower frequencies.

By default internal oscillator is turned off in user mode. You can turn on the oscillator by asserting the `oscena` signal in the Internal Oscillator IP core.

When the `oscena` input signal is asserted, the oscillator is enabled and the output can be routed to the logic array through the `clkout` output signal. When the `oscena` signal is set low, the `clkout` signal is constant high. You can analyze this delay using the TimeQuest timing analyzer.

## 2.3 PLLs Architecture and Features

### 2.3.1 PLL Architecture

The main purpose of a PLL is to synchronize the phase and frequency of the voltage-controlled oscillator (VCO) to an input reference clock.

**Figure 7. MAX 10 PLL High-Level Block Diagram**

Each clock source can come from any of the two or four clock pins located on the same side of the device as the PLL.

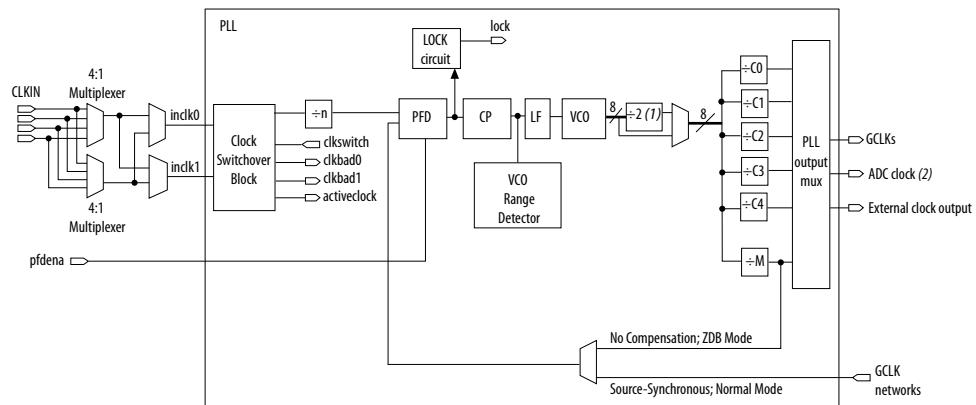

- Notes:**
- (1) This is the VCO post-scale counter K.
  - (2) Only counter C0 of PLL1 and PLL3 can drive the ADC clock.

### Phase-Frequency Detector (PFD)

The PFD has inputs from the feedback clock,  $f_{FB}$ , and the input reference clock,  $f_{REF}$ . The PLL compares the rising edge of the input reference clock to a feedback clock using a PFD. The PFD produces an up or down signal that determines whether the VCO needs to operate at a higher or lower frequency.

### Charge Pump (CP)

If the charge pump receives a logic high on the up signal, current is driven into the loop filter. If the charge pump receives a logic high on the down signal, current is drawn from the loop filter.



### Loop Filter (LF)

The loop filter converts the up and down signals from the PFD to a voltage that is used to bias the VCO. The loop filter filters out glitches from the charge pump and prevents voltage overshoot, which minimizes jitter on the VCO.

### Voltage-Controlled Oscillator (VCO)

The voltage from the charge pump determines how fast the VCO operates. The VCO is implemented as a four-stage differential ring oscillator. A divide counter,  $M$ , is inserted in the feedback loop to increase the VCO frequency,  $f_{VCO}$ , above the input reference frequency,  $f_{REF}$ .

The VCO frequency is determined using the following equation:

$$f_{VCO} = f_{REF} \times M = f_{IN} \times M/N,$$

where  $f_{IN}$  is the input clock frequency to the PLL and  $N$  is the pre-scale counter.

The VCO frequency is a critical parameter that must be between 600 and 1,300 MHz to ensure proper operation of the PLL. The Quartus Prime software automatically sets the VCO frequency within the recommended range based on the clock output and phase shift requirements in your design.

### Post-Scale Counters (C)

The VCO output can feed up to five post-scale counters (C0, C1, C2, C3, and C4). These post-scale counters allow the PLL to produce a number of harmonically-related frequencies.

### Internal Delay Elements

The MAX 10 PLLs have internal delay elements to compensate for routing on the GCLK networks and I/O buffers. These internal delays are fixed.

### PLL Outputs

The MAX 10 PLL supports up to 5 GCLK outputs and 1 dedicated external clock output. The output frequency,  $f_{OUT}$ , to the GCLK network or dedicated external clock output is determined using the following equation:

$$f_{REF} = f_{IN}/N \text{ and}$$

$$f_{OUT} = f_{VCO}/C = (f_{REF} \times M)/C = (f_{IN} \times M)/(N \times C),$$

where  $C$  is the setting on the C0, C1, C2, C3, or C4 counter.

## 2.3.2 PLL Features

**Table 4. MAX 10 PLL Features**

Feature	Support
C output counters	5
M, N, C counter sizes	1 to 512 <sup>2</sup>
<i>continued...</i>	



Feature	Support
Dedicated clock outputs	1 single-ended or 1 differential
Dedicated clock input pins	4 single-ended or 2 differential
Spread-spectrum input clock tracking	Yes <sup>3</sup>
PLL cascading	Through GCLK
Source synchronous compensation	Yes
No compensation mode	Yes
Normal compensation	Yes
Zero-delay buffer compensation	Yes
Phase shift resolution	Down to 96 ps increments <sup>4</sup>
Programmable duty cycle	Yes
Output counter cascading	Yes
Input clock switchover	Yes
User mode reconfiguration	Yes
Loss of lock detection	Yes
4:1 multiplexer CLK input selection	Yes

### 2.3.3 PLL Locations

The following figures show the physical locations of the PLLs. Every index represents one PLL in the device. The physical locations of the PLLs correspond to the coordinates in the Quartus Prime Chip Planner.

- 
- <sup>2</sup> C counters range from 1 through 512 if the output clock uses a 50% duty cycle. For any output clocks using a non-50% duty cycle, the post-scale counters range from 1 through 256.
  - <sup>3</sup> Only applicable if the input clock jitter is in the input jitter tolerance specifications.
  - <sup>4</sup> The smallest phase shift is determined by the VCO period divided by eight. For degree increments, the MAX 10 device family can shift all output frequencies in increments of at least 45°. Smaller degree increments are possible depending on the frequency and divide parameters.



**Figure 8. PLL Locations for 10M02 Device**

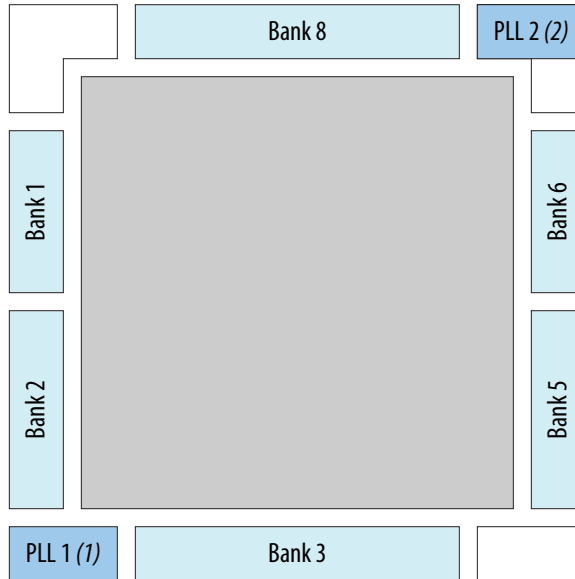

**Notes:**

- (1) Available on all packages except V36 package.
- (2) Available on U324 and V36 packages only.

**Figure 9. PLL Locations for 10M04 and 10M08 Devices**

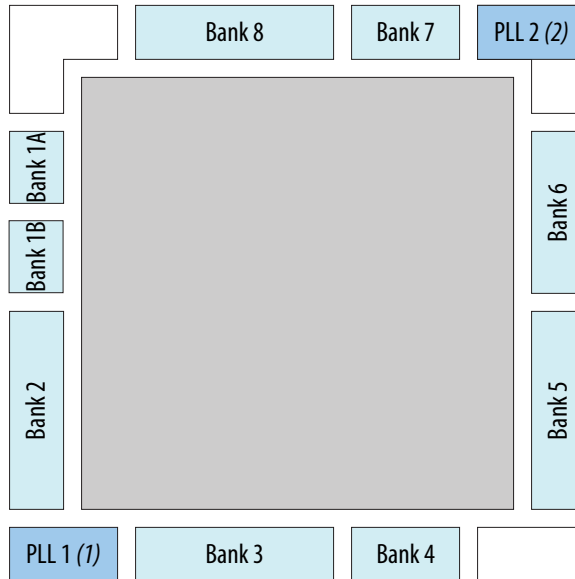

**Notes:**

- (1) Available on all packages except V81 package.
- (2) Available on F256, F484, U324, and V81 packages only.

Figure 10. PLL Locations for 10M16, 10M25, 10M40 and 10M50 Devices

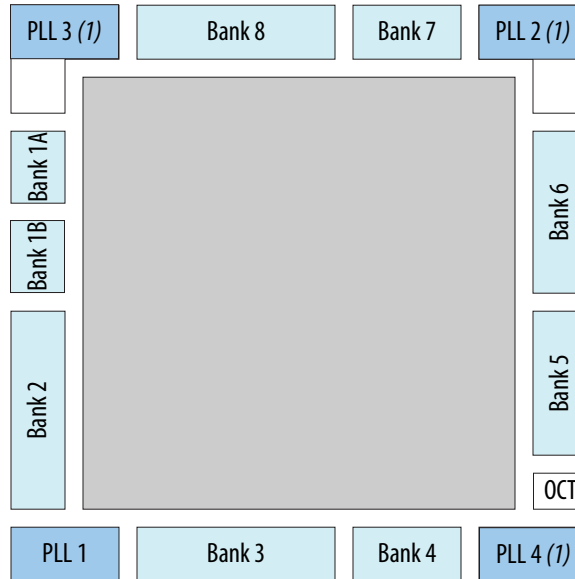

**Note:**

(1) Available on all packages except E144 and U169 packages.

### 2.3.4 Clock Pin to PLL Connections

Table 5. MAX 10 Dedicated Clock Input Pin Connectivity to PLL

Dedicated Clock Pin	PLL
CLK[0,1][p,n]	PLL1, PLL3
CLK[2,3][p,n]	PLL2, PLL4
CLK[4,5][p,n]	PLL2, PLL3
CLK[6,7][p,n]	PLL1, PLL4

### 2.3.5 PLL Counter to GCLK Connections

Table 6. MAX 10 PLL Counter Connectivity to the GCLK Networks

PLL Counter Output	GCLK
PLL1_C0	GCLK[0,3,15,18]
PLL1_C1	GCLK[1,4,16,19]
PLL1_C2	GCLK[0,2,15,17]
PLL1_C3	GCLK[1,3,16,18]
PLL1_C4	GCLK[2,4,17,19]
PLL2_C0	GCLK[5,8,10,13]
PLL2_C1	GCLK[6,9,11,14]

*continued...*





PLL Counter Output	GCLK
PLL2_C2	GCLK[5,7,10,12]
PLL2_C3	GCLK[6,8,11,13]
PLL2_C4	GCLK[7,9,12,14]
PLL3_C0 <sup>5</sup>	GCLK[0,3,10,13]
PLL3_C1 <sup>5</sup>	GCLK[1,4,11,14]
PLL3_C2 <sup>5</sup>	GCLK[0,2,10,12]
PLL3_C3 <sup>5</sup>	GCLK[1,3,11,13]
PLL3_C4 <sup>5</sup>	GCLK[2,4,12,14]
PLL4_C0 <sup>5</sup>	GCLK[5,8,15,18]
PLL4_C1 <sup>5</sup>	GCLK[6,9,16,19]
PLL4_C2 <sup>5</sup>	GCLK[5,7,15,17]
PLL4_C3 <sup>5</sup>	GCLK[6,8,16,18]
PLL4_C4 <sup>5</sup>	GCLK[7,9,17,19]

### 2.3.6 PLL Control Signals

You can use the following three signals to observe and control the PLL operation and resynchronization.

#### **pfdena**

Use the `pfdena` signal to maintain the last locked frequency so that your system has time to store its current settings before shutting down.

The `pfdena` signal controls the PFD output with a programmable gate. The PFD circuit is enabled by default. When the PFD circuit is disabled, the PLL output does not depend on the input clock, and tends to drift outside of the lock window.

#### **areset**

The `areset` signal is the reset or resynchronization input for each PLL. The device input pins or internal logic can drive these input signals.

When you assert the `areset` signal, the PLL counters reset, clearing the PLL output and placing the PLL out of lock. The VCO is then set back to its nominal setting. When the `areset` signal is deasserted, the PLL resynchronizes to its input as it relocks.

The assertion of the `areset` signal does not disable the VCO, but instead resets the VCO to its nominal value. The only time that the VCO is completely disabled is when you do not have a PLL instantiated in your design.

---

<sup>5</sup> This only applies to 10M16, 10M25, 10M40, and 10M50 devices.

### locked

The `locked` output indicates that the PLL has locked onto the reference clock and the PLL clock outputs are operating at the desired phase and frequency set in the ALTPLL IP core parameter editor.

Intel recommends using the `areset` and `locked` signals in your designs to control and observe the status of your PLL. This implementation is illustrated in the following figure.

**Figure 11. locked Signal Implementation**

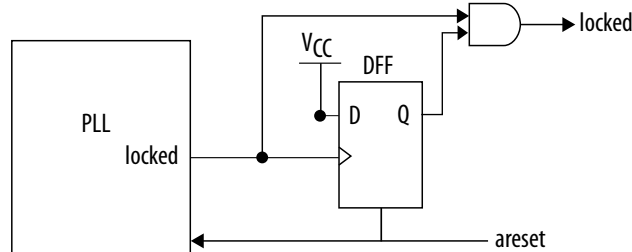

*Note:* If you use the SignalTap® II tool to probe the `locked` signal before the D flip-flop, the `locked` signal goes low only when `areset` is deasserted. If the `areset` signal is not enabled, the extra logic is not implemented in the ALTPLL IP core.

### Related Links

- [Guideline: PLL Control Signals](#) on page 34
- [PLL Control Signals Parameter Settings](#) on page 52
- [ALTPLL Ports and Signals](#) on page 56

## 2.3.7 Clock Feedback Modes

The MAX 10 PLLs support up to four different clock feedback modes. Each mode allows clock multiplication and division, phase shifting, and programmable duty cycle.

The PLL fully compensates input and output delays only when you use the dedicated clock input pins associated with a given PLL as the clock sources.

For example, when using `PLL1` in normal mode, the clock delays from one of the following clock input pins to the PLL and the PLL clock output-to-destination register are fully compensated:

- `CLK0`
- `CLK1`
- `CLK2`
- `CLK3`

When driving the PLL using the GCLK network, the input and output delays might not be fully compensated in the Quartus Prime software.

### Related Links

[Operation Modes Parameter Settings](#) on page 52



### 2.3.7.1 Source Synchronous Mode

If the data and clock arrive at the same time at the input pins, the phase relationship between the data and clock remains the same at the data and clock ports of any I/O element input register.

You can use this mode for source synchronous data transfers. Data and clock signals at the I/O element experience similar buffer delays as long as both signals use the same I/O standard.

**Figure 12. Example of Phase Relationship Between Clock and Data in Source Synchronous Mode**

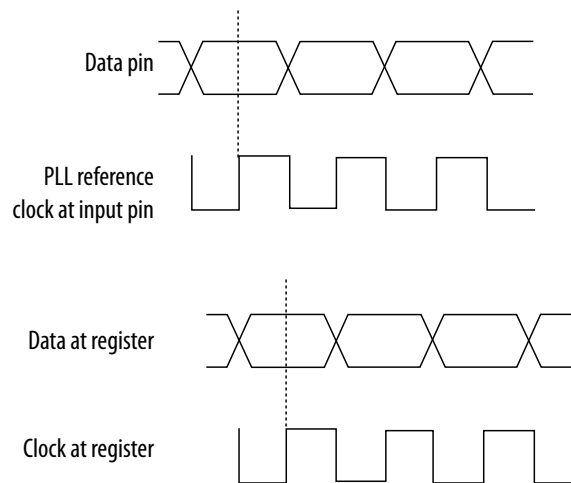

Source synchronous mode compensates for clock network delay, including any difference in delay between the following two paths:

- Data pin to I/O element register input
- Clock input pin to the PLL PFD input

For all data pins clocked by a source synchronous mode PLL, set the input pin to the register delay chain in the I/O element to zero in the Quartus Prime software. All data pins must use the **PLL COMPENSATED logic** option in the Quartus Prime software.

### 2.3.7.2 No Compensation Mode

In no compensation mode, the PLL does not compensate for any clock networks. This mode provides better jitter performance because clock feedback into the PFD does not pass through as much circuitry. Both the PLL internal and external clock outputs are phase-shifted with respect to the PLL clock input.

**Figure 13. Example of Phase Relationship Between the PLL Clocks in No Compensation Mode**

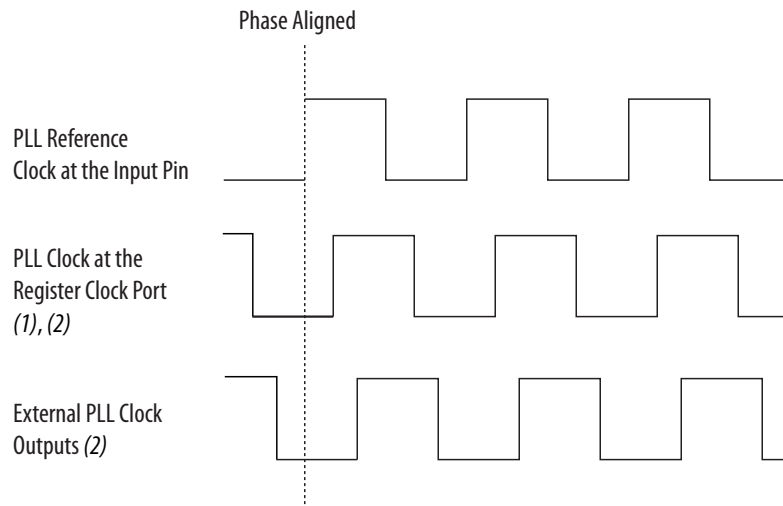

**Notes:**

- (1) Internal clocks fed by the PLL are phase-aligned to each other.
- (2) The PLL clock outputs can lead or lag the PLL input clocks. The PLL clock outputs lag the PLL input clocks depending on the routine delays.

**2.3.7.3 Normal Mode**

In normal mode, the PLL fully compensates the delay introduced by the GCLK network. An internal clock in normal mode is phase-aligned to the input clock pin. In this mode, the external clock output pin has a phase delay relative to the input clock pin. The Quartus Prime software timing analyzer reports any phase difference between the two.



**Figure 14. Example of Phase Relationship Between the PLL Clocks in Normal Compensation Mode**

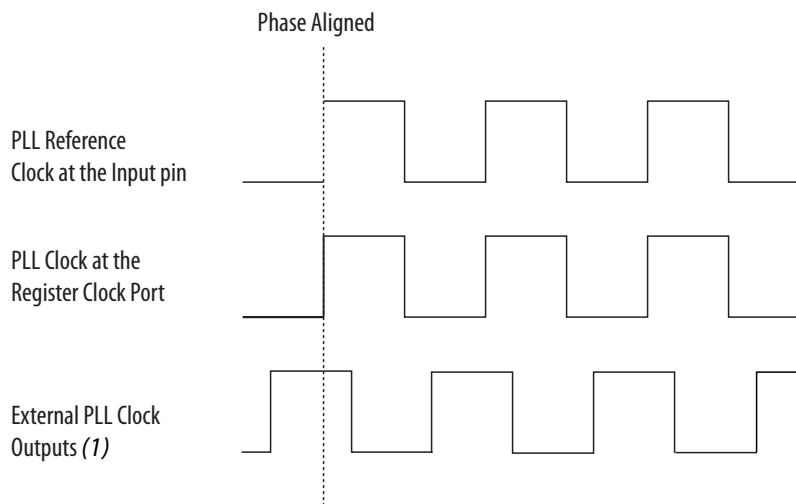

**Note:**

(1) The external clock output can lead or lag the PLL internal clock signals.

**2.3.7.4 Zero-Delay Buffer Mode**

In zero-delay buffer (ZDB) mode, the external clock output pin is phase-aligned with the clock input pin for zero delay through the device. When using this mode, use the same I/O standard for the input clock and output clocks to ensure clock alignment at the input and output pins.

**Figure 15. Example of Phase Relationship Between the PLL Clocks in ZDB Mode**

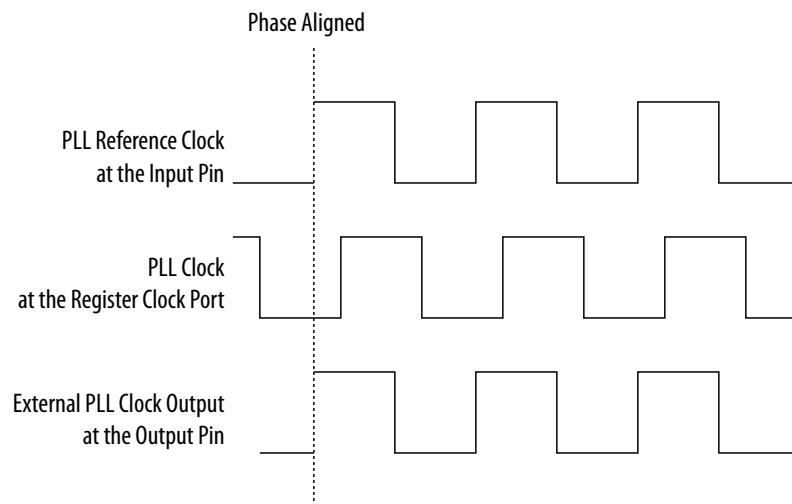

### 2.3.8 PLL External Clock Output

Each PLL in the MAX 10 devices supports one single-ended clock output or one differential clock output. Only the C0 output counter can feed the dedicated external clock outputs without going through the GCLK. Other output counters can feed other I/O pins through the GCLK.

**Figure 16. PLL External Clock Output**

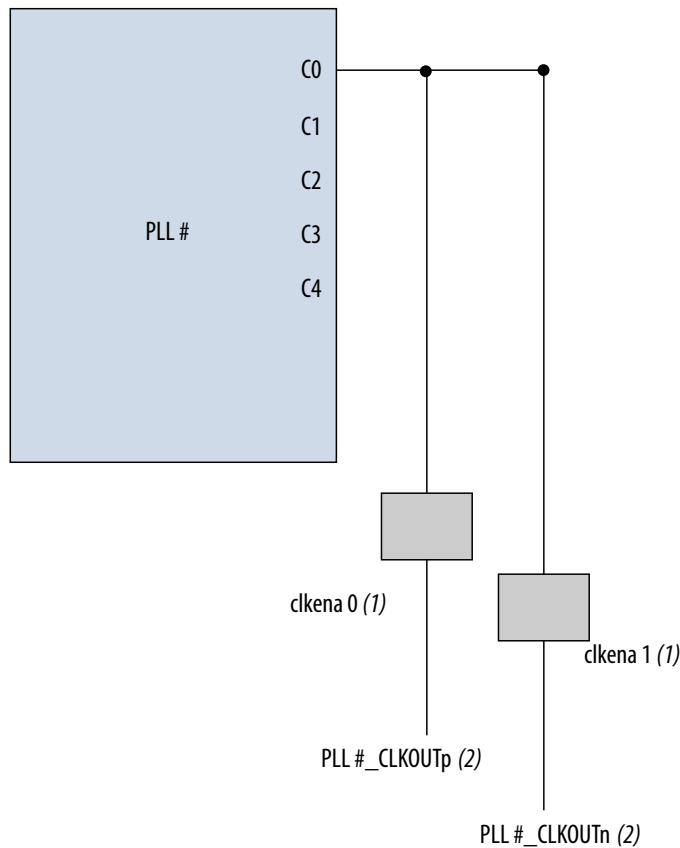

**Notes:**

- (1) These external clock enable signals are available only when using the ALTCLKCTRL IP core.
- (2) PLL#\_CLKOUTp and PLL#\_CLKOUTn pins are dual-purpose I/O pins that you can use as one single-ended or one differential clock output.

Each pin of a differential output pair is 180° out of phase. To implement the 180° out-of-phase pin in a pin pair, the Quartus Prime software places a NOT gate in the design into the I/O element.

The clock output pin pairs support the following I/O standards:



- Same I/O standard as the standard output pins (in the top and bottom banks)
- LVDS
- LVPECL
- Differential high-speed transceiver logic (HSTL)
- Differential SSTL

The MAX 10 PLLs can drive out to any regular I/O pin through the GCLK. You can also use the external clock output pins as general-purpose I/O pins if you do not require any external PLL clocking.

#### Related Links

##### [MAX 10 General Purpose I/O User Guide](#)

Provides more information about the I/O standards supported by the PLL clock output pins.

### 2.3.9 ADC Clock Input from PLL

Only the C0 output counter from PLL1 and PLL3 can drive the ADC clock.

Counter C0 has dedicated path to the ADC clock input.

### 2.3.10 Spread-Spectrum Clocking

The MAX 10 devices allow a spread-spectrum input with typical modulation frequencies. However, the device cannot automatically detect that the input is a spread-spectrum signal. Instead, the input signal looks like deterministic jitter at the input of the PLL.

The MAX 10 PLLs can track a spread-spectrum input clock if the input signal meets the following conditions:

- The input signal is within the input jitter tolerance specifications.
- The modulation frequency of the input clock is below the PLL bandwidth as specified in the Fitter report.

MAX 10 devices cannot generate spread-spectrum signals internally.

### 2.3.11 PLL Programmable Parameters

#### 2.3.11.1 Programmable Duty Cycle

The programmable duty cycle allows PLLs to generate clock outputs with a variable duty cycle. This feature is supported on the PLL post-scale counters.

The duty cycle setting is achieved by a low and high time-count setting for the post-scale counters. To determine the duty cycle choices, the Quartus Prime software uses the frequency input and the required multiply or divide rate.

The post-scale counter value determines the precision of the duty cycle. The precision is defined as 50% divided by the post-scale counter value. For example, if the C0 counter is 10, steps of 5% are possible for duty cycle choices between 5 to 90%.



Combining the programmable duty cycle with programmable phase shift allows the generation of precise nonoverlapping clocks.

#### Related Links

[Post-Scale Counters \(C0 to C4\)](#) on page 42

Provides more information about configuring the duty cycle of the post-scale counters in real time.

### 2.3.11.2 Programmable Bandwidth

The PLL bandwidth is the measure of the PLL's ability to track the input clock and its associated jitter. The MAX 10 PLLs provide advanced control of the PLL bandwidth using the programmable characteristics of the PLL loop, including loop filter and charge pump. The 3-dB frequency of the closed-loop gain in the PLL determines the PLL bandwidth. The bandwidth is approximately the unity gain point for open loop PLL response.

#### Related Links

- [Programmable Bandwidth with Advanced Parameters](#) on page 40
- [Charge Pump and Loop Filter](#) on page 43  
Provides more information about the PLL components to update PLL bandwidth in real time.
- [Programmable Bandwidth Parameter Settings](#) on page 53

### 2.3.11.3 Programmable Phase Shift

The MAX 10 devices use phase shift to implement clock delays. You can phase shift the output clocks from the MAX 10 PLLs using one of the following methods:

- Fine resolution using VCO phase taps
- Coarse resolution using counter starting time

The VCO phase output and counter starting time are the most accurate methods of inserting delays. These methods are purely based on counter settings, which are independent of process, voltage, and temperature.

The MAX 10 devices support dynamic phase shifting of VCO phase taps only. The phase shift is configurable for any number of times. Each phase shift takes about one scanclk cycle, allowing you to implement large phase shifts quickly.

#### Fine Resolution Phase Shift

Fine resolution phase shifts are implemented by allowing any of the output counters (C[4..0]) or the M counter to use any of the eight phases of the VCO as the reference clock. This allows you to adjust the delay time with a fine resolution. The following equation shows the minimum delay time that you can insert using this method.

**Figure 17. Fine Resolution Phase Shift Equation**

$f_{REF}$  in this equation is the input reference clock frequency

$$\Phi_{fine} = \frac{T_{VCO}}{8} = \frac{1}{8f_{VCO}} = \frac{1}{8} \times \frac{N}{M \times f_{REF}}$$





For example, if  $f_{REF}$  is 100 MHz,  $N = 1$ , and  $M = 8$ , then  $f_{VCO} = 800$  MHz, and  $\Phi_{fine} = 156.25$  ps. The PLL operating frequency defines this phase shift, a value that depends on the reference clock frequency and counter settings.

The following figure shows an example of phase shift insertion using the fine resolution through VCO phase taps method. The eight phases from the VCO are shown and labeled for reference.

**Figure 18. Example of Delay Insertion Using VCO Phase Output and Counter Delay Time**

The observations in this example are as follows:

- CLK0 is based on 0° phase from the VCO and has the  $C$  value for the counter set to one.
- CLK1 signal is divided by four, two VCO clocks for high time and two VCO clocks for low time. CLK1 is based on the 135° phase tap from the VCO and has the  $C$  value for the counter set to one.
- CLK2 signal is also divided by four. In this case, the two clocks are offset by 3  $\Phi_{fine}$ . CLK2 is based on the 0° phase from the VCO but has the  $C$  value for the counter set to three. This creates a delay of two  $\Phi_{coarse}$  (two complete VCO periods).

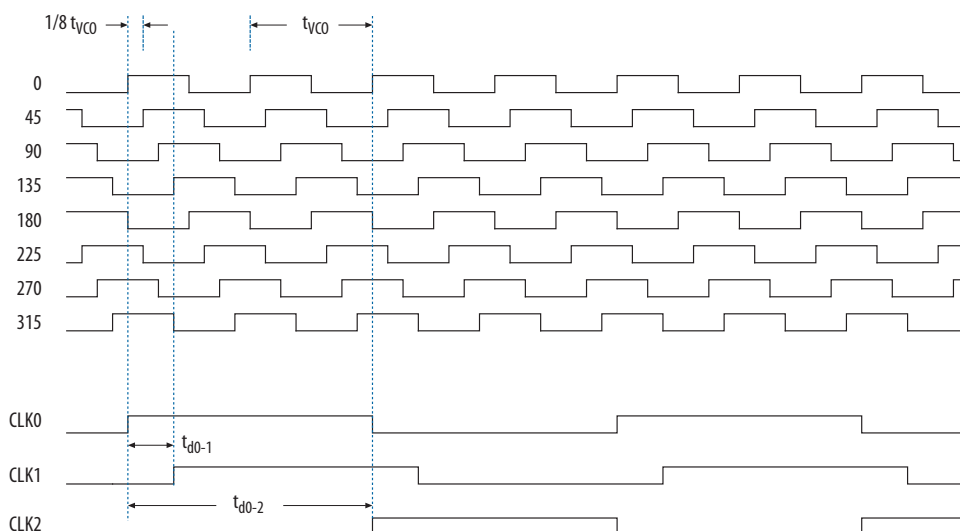

**Coarse Resolution Phase Shift**

Coarse resolution phase shifts are implemented by delaying the start of the counters for a predetermined number of counter clocks.

**Figure 19. Coarse Resolution Phase Shift Equation**

$C$  in this equation is the count value set for the counter delay time—the initial setting in the PLL usage section of the compilation report in the Quartus Prime software. If the initial value is 1,  $C - 1 = 0^\circ$  phase shift.

$$\Phi_{coarse} = \frac{C - 1}{f_{VCO}} = \frac{(C - 1)N}{Mf_{REF}}$$



### Related Links

- [Dynamic Phase Configuration Implementation](#) on page 45
- [Dynamic Phase Configuration Counter Selection](#) on page 46
- [Dynamic Phase Configuration with Advanced Parameters](#) on page 46
- [Dynamic Phase Configuration Parameter Settings](#) on page 54  
Provides more information about the ALTPLL IP core parameter settings in the Quartus Prime software.
- [ALTPLL\\_RECONFIG Parameters](#) on page 59  
Provides more information about the ALTPLL\_RECONFIG IP core parameter settings in the Quartus Prime software.

## 2.3.12 Clock Switchover

The clock switchover feature allows the PLL to switch between two reference input clocks. Use this feature for clock redundancy or for a dual-clock domain application where a system turns on the redundant clock if the previous clock stops running. The design can perform clock switchover automatically when the clock is no longer toggling or based on a user-controlled signal, `clkswitch`.

The following clock switchover modes are supported in MAX 10 PLLs:

- Automatic switchover—The clock sense circuit monitors the current reference clock. If the current reference clock stops toggling, the reference clock automatically switches to `inclk0` or `inclk1` clock.
- Manual clock switchover—The `clkswitch` signal controls the clock switchover. When the `clkswitch` signal goes from logic low to high, and stays high for at least three clock cycles, the reference clock to the PLL switches from `inclk0` to `inclk1`, or vice-versa.
- Automatic switchover with manual override—This mode combines automatic switchover and manual clock switchover. When the `clkswitch` signal goes high, it overrides the automatic clock switchover function. As long as the `clkswitch` signal is high, any further switchover action is blocked.

### Related Links

- [Guideline: Clock Switchover](#) on page 35
- [Clock Switchover Parameter Settings](#) on page 53

### 2.3.12.1 Automatic Clock Switchover

The MAX 10 PLLs support a fully configurable clock switchover capability.



**Figure 20. Automatic Clock Switchover Circuit Block Diagram**

This figure shows a block diagram of the automatic switchover circuit built into the PLL.

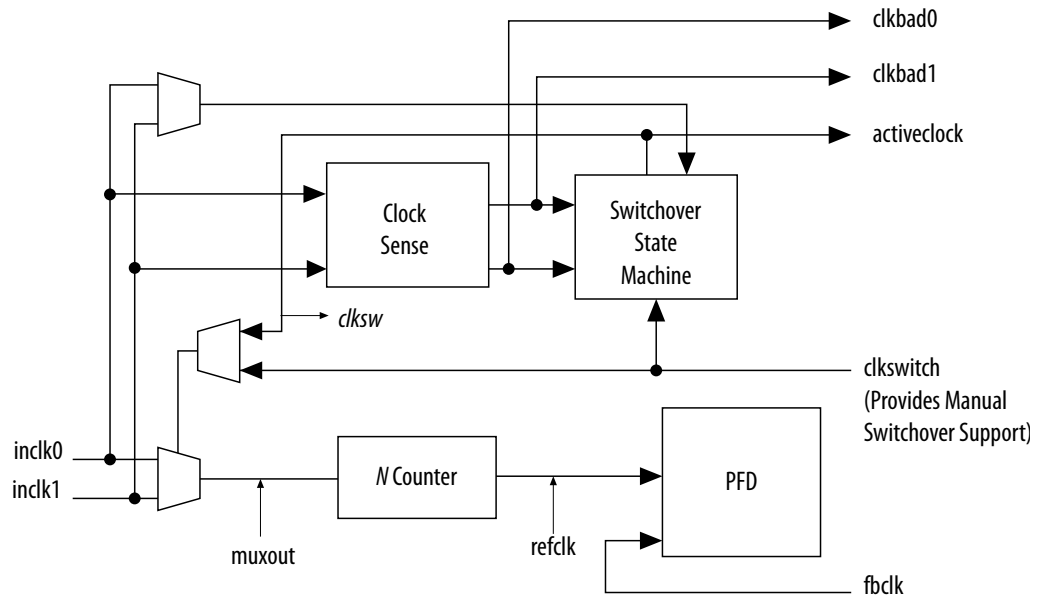

When the current reference clock is not present, the clock sense block automatically switches to the backup clock for PLL reference. You can select a clock source at the backup clock by connecting it to the `inclk1` port of the PLL in your design.

The clock switchover circuit also sends out three status signals—`clkbad[0]`, `clkbad[1]`, and `activeclock`—from the PLL to implement a custom switchover circuit in the logic array.

In automatic switchover mode, the `clkbad[0]` and `clkbad[1]` signals indicate the status of the two clock inputs. When the `clkbad[0]` and `clkbad[1]` signals are asserted, the clock sense block detects that the corresponding clock input has stopped toggling. These two signals are not valid if the frequency difference between `inclk0` and `inclk1` is greater than 20%.

The `activeclock` signal indicates which of the two clock inputs (`inclk0` or `inclk1`) is selected as the reference clock to the PLL. When the frequency difference between the two clock inputs is more than 20%, the `activeclock` signal is the only valid status signal.

**Note:** Glitches in the input clock may cause the frequency difference between the input clocks to be more than 20%.

When the current reference clock to the PLL stops toggling, use the switchover circuitry to automatically switch from `inclk0` to `inclk1` that runs at the same frequency. This automatic switchover can switch back and forth between the `inclk0` and `inclk1` clocks any number of times when one of the two clocks fails and the other clock is available.

For example, in applications that require a redundant clock with the same frequency as the reference clock, the switchover state machine generates a signal (`clksw`) that controls the multiplexer select input. In this case, `inclk1` becomes the reference clock for the PLL.

When using automatic clock switchover mode, the following requirements must be satisfied:

- Both clock inputs must be running when the FPGA is configured.
- The period of the two clock inputs differ by no more than 20%.

If the current clock input stops toggling while the other clock is also not toggling, switchover is not initiated and the `clkbad[0..1]` signals are not valid. If both clock inputs do not have the same frequency, but their period difference is within 20%, the clock sense block detects when a clock stops toggling. However, the PLL might lose lock after the switchover completes and needs time to relock.

*Note:* Intel recommends resetting the PLL using the `areset` signal to maintain the phase relationships between the PLL input and output clocks when using clock switchover.

**Figure 21. Example of Automatic Switchover After Loss of Clock Detection**

This figure shows an example waveform of the switchover feature in automatic switchover mode. In this example, the `inclk0` signal remains low. After the `inclk0` signal remains low for approximately two clock cycles, the clock sense circuitry drives the `clkbad[0]` signal high. Since the reference clock signal is not toggling, the switchover state machine controls the multiplexer through the `clksw` signal to switch to the backup clock, `inclk1`.

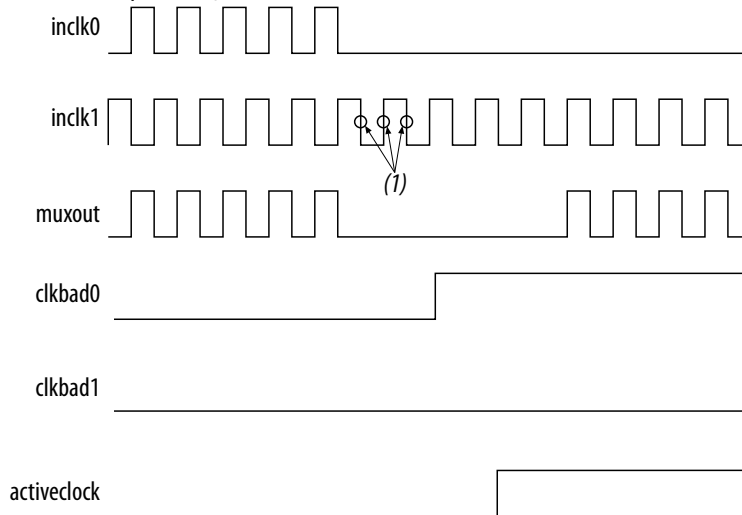

**Note:**

(1) Switchover is enabled on the falling edge of `inclk0` or `inclk1`, depending on which clock is available. In this figure, switchover is enabled on the falling edge of `inclk1`.

**2.3.12.2 Automatic Switchover with Manual Override**

In automatic switchover with manual override mode, you can use the `clkswitch` signal for user- or system-controlled switch conditions. You can use this mode for same-frequency switchover, or to switch between inputs of different frequencies.



For example, if `inclk0` is 66 MHz and `inclk1` is 200 MHz, you must control the switchover using the `clkswitch` signal. The automatic clock sense circuitry cannot monitor clock input (`inclk0` and `inclk1`) frequencies with a frequency difference of more than 20%.

This feature is useful when clock sources originate from multiple cards on the backplane, requiring a system-controlled switchover between frequencies of operation.

You must choose the backup clock frequency and set the `M`, `N`, and `C` counters so that the VCO operates within the recommended frequency range.

The following figure shows a clock switchover waveform controlled by the `clkswitch` signal. In this case, both clock sources are functional and `inclk0` is selected as the reference clock. The `clkswitch` signal goes high, which starts the switchover sequence. On the falling edge of `inclk0`, the counter's reference clock, `muxout`, is gated off to prevent clock glitching. On the falling edge of `inclk1`, the reference clock multiplexer switches from `inclk0` to `inclk1` as the PLL reference. The `activeclock` signal is asserted to indicate the clock that is currently feeding the PLL, which is `inclk1`.

In automatic override with manual switchover mode, the `activeclock` signal mirrors the `clkswitch` signal. Since both clocks are still functional during the manual switch, neither `clkbad` signal goes high. Because the switchover circuit is positive-edge sensitive, the falling edge of the `clkswitch` signal does not cause the circuit to switch back from `inclk1` to `inclk0`. When the `clkswitch` signal goes high again, the process repeats.

**Figure 22. Example of Clock Switchover Using the `clkswitch` (Manual) Control**

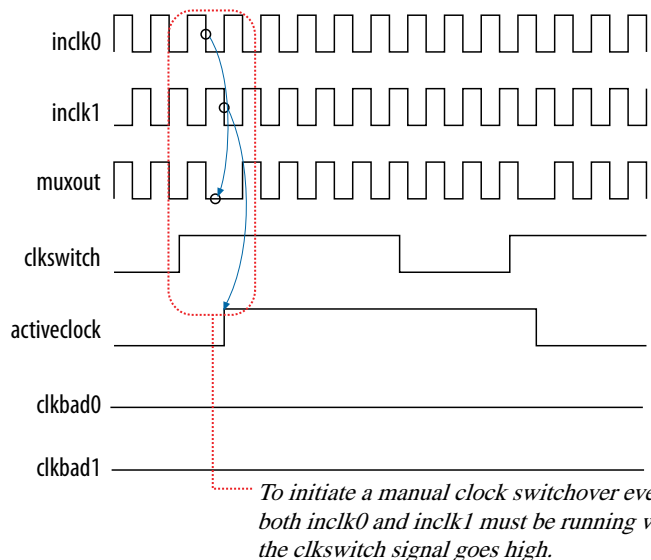

The `clkswitch` signal and automatic switch work only if the clock being switched to is available. If the clock is not available, the state machine waits until the clock is available.

### 2.3.12.3 Manual Clock Switchover

In manual clock switchover mode, the `clkswitch` signal controls whether `inclk0` or `inclk1` is selected as the input clock to the PLL. By default, `inclk0` is selected.

A clock switchover event is initiated when the `clkswitch` signal transitions from logic low to logic high, and is being held high for at least three `inclk` cycles. You must bring the `clkswitch` signal back to low again to perform another switchover event. If you do not require another switchover event, you can leave the `clkswitch` signal in a logic high state after the initial switch. Pulsing the `clkswitch` signal high for at least three `inclk` cycles performs another switchover event.

If `inclk0` and `inclk1` have different frequencies and are always running, the minimum amount of time for which `clkswitch` signal is high must be greater than or equal to three of the slower-frequency `inclk0` and `inclk1` cycles.

### 2.3.13 PLL Cascading

#### Related Links

Guideline: [PLL Cascading](#) on page 35

#### 2.3.13.1 PLL-to-PLL Cascading

Two PLLs are cascaded to each other through the clock network. If your design cascades PLLs, the source (upstream) PLL must have a low-bandwidth setting and the destination (downstream) PLL must have a high-bandwidth setting.

#### 2.3.13.2 Counter-to-Counter Cascading

The MAX 10 PLLs support post-scale counter cascading to create counters larger than 512. This is implemented by feeding the output of one C counter into the input of the next C counter.

**Figure 23. Counter-to-Counter Cascading**

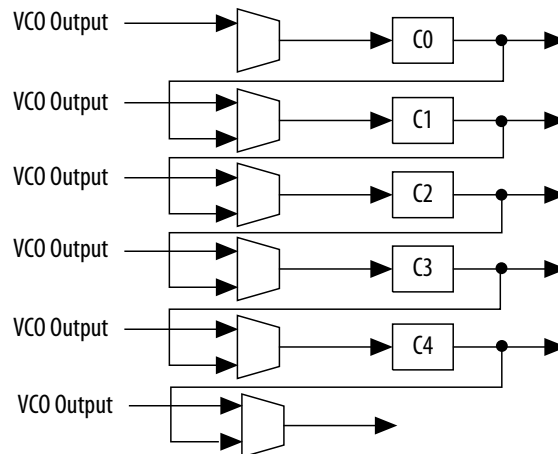

When cascading counters to implement a larger division of the high-frequency VCO clock, the cascaded counters behave as one counter with the product of the individual counter settings.



For example, if  $C0 = 4$  and  $C1 = 2$ , the cascaded value is  $C0 \times C1 = 8$ .

The Quartus Prime software automatically sets all the post-scale counter values for cascading in the configuration file. Post-scale counter cascading cannot be performed using PLL reconfiguration.

### 2.3.14 PLL Reconfiguration

The PLLs use several divide counters and different VCO phase taps to perform frequency synthesis and phase shifts. In MAX 10 PLLs, you can reconfigure both counter settings and phase shift the PLL output clock in real time. You can also change the charge pump and loop filter components, which dynamically affects the PLL bandwidth.

The following PLL components are configurable in real time:

- Pre-scale counter ( $N$ )
- Feedback counter ( $M$ )
- Post-scale output counters ( $C0-C4$ )
- Charge pump current ( $I_{CP}$ )
- Loop filter components ( $R, C$ )

You can use these PLL components to update the following settings in real time without reconfiguring the entire FPGA:

- Output clock frequency
- PLL bandwidth
- Phase shift

The ability to reconfigure the PLL in real time is useful in applications that may operate in multiple frequencies. It is also useful in prototyping environments, allowing you to sweep PLL output frequencies and dynamically adjust the output clock phase.

For instance, a system generating test patterns is required to generate and send patterns at 75 or 150 MHz, depending on the requirements of the device under test. Reconfiguring the PLL components in real time allows you to switch between two such output frequencies in a few microseconds.

You can also use this feature to adjust clock-to-out ( $t_{CO}$ ) delays in real time by changing the PLL output clock phase shift. This approach eliminates the need to regenerate a configuration file with the new PLL settings.

**Figure 24. PLL Reconfiguration Scan Chain**

This figure shows the dynamic adjustment of the PLL counter settings by shifting their new settings into a serial shift register chain or scan chain. Serial data shifts to the scan chain via the `scandata` port, and shift registers are clocked by `scandclk`. The maximum `scandclk` frequency is 100 MHz. After shifting the last bit of data, asserting the `configupdate` signal for at least one `scandclk` clock cycle synchronously updates the PLL configuration bits with the data in the scan registers.

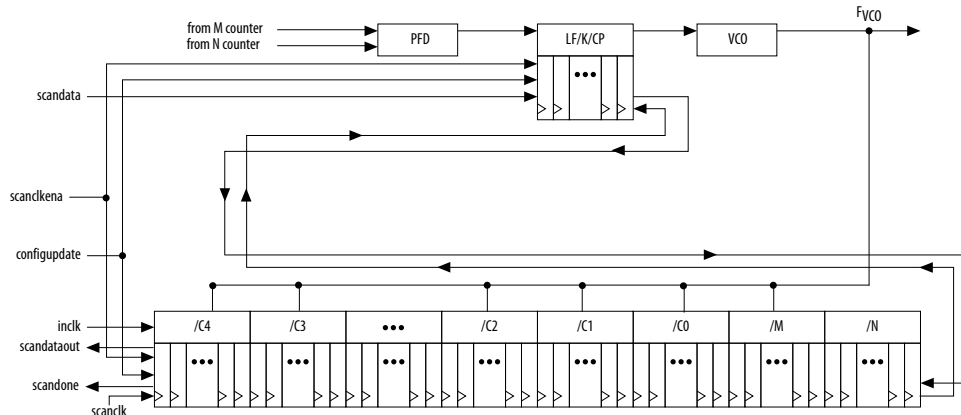

The counter settings are updated synchronously to the clock frequency of the individual counters. Therefore, not all counters update simultaneously.

The dynamic reconfiguration scheme uses configuration files, such as the Hexadecimal-format file (**.hex**) or the Memory Initialization file (**.mif**). These files are used together with the ALTPLL\_RECONFIG IP core to perform the dynamic reconfiguration.

**Related Links**

- [Guideline: .mif Streaming in PLL Reconfiguration](#) on page 37
- [PLL Dynamic Reconfiguration Implementation](#) on page 41
- [PLL Dynamic Reconfiguration Parameter Settings](#) on page 54  
Provides more information about the ALTPLL IP core parameter settings in the Quartus Prime software.
- [ALTPLL\\_RECONFIG Parameters](#) on page 59  
Provides more information about the ALTPLL\_RECONFIG IP core parameter settings in the Quartus Prime software.





## 3 MAX 10 Clocking and PLL Design Considerations

---

### 3.1 Clock Networks Design Considerations

#### 3.1.1 Guideline: Clock Enable Signals

Intel recommends using the `clkena` signals when switching the clock source to the PLLs or GCLK. The recommended sequence is as follows:

1. Disable the primary output clock by deasserting the `clkena` signal.
2. Switch to the secondary clock using the dynamic select signals of the clock control block.
3. Allow some clock cycles of the secondary clock to pass before reasserting the `clkena` signal. The exact number of clock cycles to wait before enabling the secondary clock depends on your design. You can build a custom logic to ensure a glitch-free transition when switching between different clock sources.

#### Related Links

- [Clock Enable Signals](#) on page 11
- [ALTCLKCTRL Parameters](#) on page 50
- [ALTCLKCTRL Ports and Signals](#) on page 51

#### 3.1.2 Guideline: Connectivity Restrictions

The following guidelines describe the restrictions associated with the signal sources that can drive the `inclk` input:

- You must use the `inclk` ports that are consistent with the `clkselect` ports.
- When you are using multiple input sources, the `inclk` ports can only be driven by the dedicated clock input pins and the PLL clock outputs.
- If the clock control block feeds any `inclk` port of another clock control block, both clock control blocks must be able to be reduced to a single clock control block of equivalent functionality.
- When you are using the glitch-free switchover feature, the clock you are switching from must be active. If the clock is not active, the switchover circuit cannot transition from the clock you originally selected.

### 3.2 Internal Oscillator Design Considerations

#### 3.2.1 Guideline: Connectivity Restrictions

You cannot drive the PLLs with internal oscillator.



## 3.3 PLLs Design Considerations

### 3.3.1 Guideline: PLL Control Signals

You must include the `areset` signal in your designs if one of the following conditions is true:

- PLL reconfiguration or clock switchover is enabled in your design.
- Phase relationships between the PLL input clock and output clocks must be maintained after a loss-of-lock condition.
- The input clock to the PLL is toggling or unstable at power-up.
- The `areset` signal is asserted after the input clock is stable and within specifications.

#### Related Links

[PLL Control Signals](#) on page 17

### 3.3.2 Guideline: Connectivity Restrictions

To comply with simultaneous switching noise (SSN) design guideline, Intel recommends that you do not use unterminated I/O in the same bank as the input clock signal to the PLL.

#### Related Links

[Guidelines: Clock and Asynchronous Control Input Signal](#)

Provides more information about using I/O connectivity restrictions.

### 3.3.3 Guideline: Self-Reset

The lock time of a PLL is the amount of time required by the PLL to attain the target frequency and phase relationship after device power-up, after a change in the PLL output frequency, or after resetting the PLL.

A PLL might lose lock for a number of reasons, such as the following causes:

- Excessive jitter on the input clock.
- Excessive switching noise on the clock inputs of the PLL.
- Excessive noise from the power supply, causing high output jitter and possible loss of lock.
- A glitch or stopping of the input clock to the PLL.
- Resetting the PLL by asserting the `areset` port of the PLL.
- An attempt to reconfigure the PLL might cause the `M` counter, `N` counter, or phase shift to change, causing the PLL to lose lock. However, changes to the post-scale counters do not affect the PLL `locked` signal.
- PLL input clock frequency drifts outside the lock range specification.
- The PFD is disabled using the `pfdena` port. When this happens, the PLL output phase and frequency tend to drift outside of the lock window.

The ALTPLL IP core allows you to monitor the PLL locking process using a lock signal named `locked` and also allows you to set the PLL to self-reset on loss of lock.



### 3.3.4 Guideline: Output Clocks

Each MAX 10 PLL supports up to five output clocks. You can use the output clock port as a core output clock or an external output clock port. The core output clock feeds the FPGA core and the external output clock feeds the dedicated pins on the FPGA.

The ALTPLL IP core does not have a dedicated output enable port. You can disable the PLL output using the `areset` signal to disable the PLL output counters.

### 3.3.5 Guideline: PLL Cascading

Consider the following guidelines when cascading PLLs:

- Set the primary PLL to low bandwidth to help filter jitter. Set the secondary PLL to high bandwidth to track the jitter from the primary PLL. You can view the Quartus Prime software compilation report file to ensure the PLL bandwidth ranges do not overlap. If the bandwidth ranges overlap, jitter peaking can occur in the cascaded PLL scheme.

*Note:* You can get an estimate of the PLL deterministic jitter and static phase error (SPE) by using the TimeQuest Timing Analyzer in the Quartus Prime software. Use the SDC command `derive_clock_uncertainty` to generate a report titled `PLLJ_PLLSPE_INFO.txt` in your project directory. Then, use `set_clock_uncertainty` command to add jitter and SPE values to your clock constraints.

- Keep the secondary PLL in a reset state until the primary PLL has locked to ensure the phase settings are correct on the secondary PLL.
- You cannot connect any of the `inclk` ports of any PLLs in a cascaded scheme to the clock outputs from PLLs in the cascaded scheme.

#### Related Links

[PLL Cascading](#) on page 30

### 3.3.6 Guideline: Clock Switchover

Use the following guidelines to design with clock switchover in PLLs:

- Clock loss detection and automatic clock switchover requires that the frequency difference between `inclk0` and `inclk1` is within 20% range. Failing to meet this requirement causes the `clkbad[0]` and `clkbad[1]` signals to function improperly.
- When using manual clock switchover, the frequency difference between `inclk0` and `inclk1` can be more than 20%. However, differences between the two clock sources (frequency, phase, or both) can cause the PLL to lose lock. Resetting the PLL ensures that the correct phase relationships are maintained between the input and output clocks.
- Both `inclk0` and `inclk1` must be running when the `clkswitch` signal goes high to start the manual clock switchover event. Failing to meet this requirement causes the clock switchover to malfunction.
- Applications that require a clock switchover feature and a small frequency drift must use a low-bandwidth PLL. When referencing input clock changes, the low-bandwidth PLL reacts slower than a high-bandwidth PLL. When the switchover happens, the low-bandwidth PLL propagates the stoppage of the clock to the output at a slower speed than the high-bandwidth PLL. The low-bandwidth PLL filters out jitter on the reference clock. However, be aware that the low-bandwidth PLL also increases lock time.
- After a switchover occurs, there might be a finite resynchronization period for the PLL to lock onto a new clock. The exact amount of time it takes for the PLL to relock depends on the PLL configuration.
- The phase relationship between the input clock to the PLL and output clock from the PLL is important in your design. Assert `areset` for 10 ns after performing a clock switchover. Wait for the locked signal (or gated lock) to go high before reenabling the output clocks from the PLL.
- Disable the system during switchover if the system is not tolerant of frequency variations during the PLL resynchronization period. You can use the `clkbad[0]` and `clkbad[1]` status signals to turn off the PFD (`pfdena = 0`) so that the VCO maintains its last frequency. You can also use the switchover state machine to switch over to the secondary clock. After enabling the PFD, the output clock enable signals (`clkena`) can disable clock outputs during the switchover and resynchronization period. After the lock indication is stable, the system can reenabling the output clock or clocks.
- The VCO frequency gradually decreases when the primary clock is lost and then increases as the VCO locks onto the secondary clock, as shown in the following figure. After the VCO locks onto the secondary clock, some overshoot can occur (an over-frequency condition) in the VCO frequency.

**Figure 25. VCO Switchover Operating Frequency**

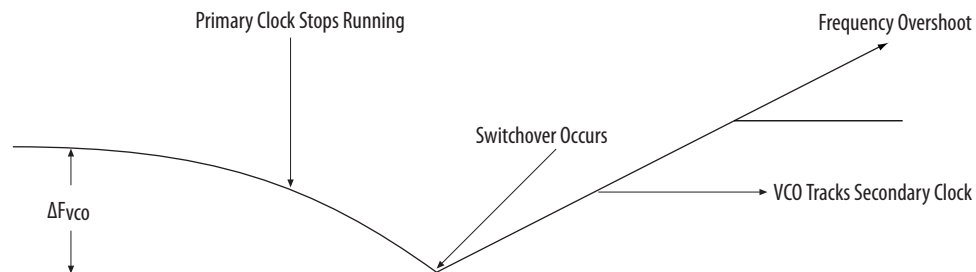

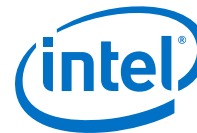

#### Related Links

- [Clock Switchover](#) on page 26
- [Clock Switchover Parameter Settings](#) on page 53

### 3.3.7 Guideline: .mif Streaming in PLL Reconfiguration

Consider the following guidelines when using .mif streaming in PLL reconfiguration:

- 10M02 devices do not support .mif streaming in PLL reconfiguration due to flash size limitation. Intel recommends using an external flash.
- 10M04, 10M08, 10M16, 10M25, 10M40, and 10M50 devices only support .mif streaming in single image mode. Intel recommends using an external flash for dual image mode. The MAX 10 devices do not support using both dual image mode and PLL reconfiguration with .mif simultaneously.

#### Related Links

[PLL Reconfiguration](#) on page 31

### 3.3.8 Guideline: scandone Signal for PLL Reconfiguration

scandone signal must be low before the second PLL reconfiguration. For scandone signal to go low, PLL areset signal must be asserted.



## 4 MAX 10 Clocking and PLL Implementation Guides

---

### 4.1 ALTCLKCTRL IP Core

The clock control block (ALTCLKCTRL) IP core is a clock control function for configuring the clock control block.

The common applications of the ALTCLKCTRL IP core are as follows:

- Dynamic clock source selection—When using the clock control block, you can select the dynamic clock source that drives the global clock network.
- Dynamic power-down of a clock network—The dynamic clock enable or disable feature allows internal logic to power down the clock network. When a clock network is powered down, all the logic fed by that clock network is not toggling, thus reducing the overall power consumption of the device.

The ALTCLKCTRL IP core provides the following features:

- Supports clock control block operation mode specifications
- Supports specification of the number of input clock sources
- Provides an active high clock enable control input

#### Related Links

- [Introduction to Intel FPGA IP Cores](#)  
Provides general information about all Intel FPGA IP cores, including parameterizing, generating, upgrading, and simulating IP cores.
- [Creating Version-Independent IP and Qsys Simulation Scripts](#)  
Create simulation scripts that do not require manual updates for software or IP version upgrades.
- [Project Management Best Practices](#)  
Guidelines for efficient management and portability of your project and IP files.
- [MAX 10 Clocking and PLL User Guide Archives](#) on page 66  
Provides a list of user guides for previous versions of the ALTCLKCTRL IP core.

### 4.2 ALTPLL IP Core

The ALTPLL IP core specifies the PLL circuitry. You can use this IP core to configure the PLL types, operation modes, and advanced features of the PLL.

#### Related Links

- [Introduction to Intel FPGA IP Cores](#)  
Provides general information about all Intel FPGA IP cores, including parameterizing, generating, upgrading, and simulating IP cores.
- [Creating Version-Independent IP and Qsys Simulation Scripts](#)



Create simulation scripts that do not require manual updates for software or IP version upgrades.

- [Project Management Best Practices](#)  
Guidelines for efficient management and portability of your project and IP files.
- [MAX 10 Clocking and PLL User Guide Archives](#) on page 66  
Provides a list of user guides for previous versions of the ALTPLL IP core.

### 4.2.1 Expanding the PLL Lock Range

The PLL lock range is between the minimum (Freq min lock parameter) and maximum (Freq max lock parameter) input frequency values for which the PLL can achieve lock. Changing the input frequency might cause the PLL to lose lock, but if the input clock remains within the minimum and maximum frequency specifications, the PLL is able to achieve lock. The Quartus Prime software shows these input frequency values in the PLL Summary report located under the Resource Section of the Fitter folder in the Compilation Report.

The Quartus Prime software does not necessarily pick values for the PLL parameters to maximize the lock range. For example, when you specify a 75 MHz input clock in the ALTPLL parameter editor, the actual PLL lock range might be between 70 MHz to 90 MHz. If your application requires a lock range of 50 MHz to 100 MHz, the default lock range of this PLL is insufficient.

For devices that support clock switchover in PLLs, you can use the ALTPLL IP core parameter editor to maximize the lock range.

To extract valid parameter values to maximize your PLL lock range, perform the following steps:

1. In the schematic editor, double-click the ALTPLL instance in your design to open the ALTPLL parameter editor.
2. On the **General/Modes** page, for **What is the frequency of the inclk0 input?**, type the value of the low end of your desired PLL lock range.  
For example, if your application requires a lock range of 50 MHz to 100 MHz, type 50 MHz.
3. On the **Inputs/Lock** page, turn on **Create output file(s) using the 'Advanced' PLL parameters**.
4. On the **Clock switchover** page, turn on **Create an 'inclk1' input for a second input clock** and enter the high end of your lock range as the frequency for `inclk1`.  
For example, if your application requires a lock range of 50 MHz to 100 MHz, type 100 MHz.
5. Set the rest of the parameters in the remaining pages of the ALTPLL IP core parameter editor.
6. Compile your project and note the lock range shown in the PLL Summary report. If it is satisfactory, note all of the values for the PLL from this report, such as the  $M$  value,  $N$  value, charge pump current, loop filter resistance, and loop filter capacitance.
7. In the schematic editor, double-click the ALTPLL instance in your design to open the ALTPLL parameter editor.



8. On the **Clock switchover** page, turn off **Create an 'inclk1' input for a second input clock**.
9. Click **Finish** to update the PLL wrapper file.
10. In a text editor, open the PLL wrapper file. Modify all of the values for the parameters listed in step 6. Save the changes.
  - If the wrapper file is in Verilog format, go to the **defparam** section.
  - If the wrapper file is in VHDL HDL, go to the **Generic Map** section.
11. Compile your project.
12. Check the PLL Summary report to confirm that the PLL lock range meets your requirements. The modified PLL should have the desired lock range.

If your input clock frequency is too close to the end of the desired PLL lock range—for example the low end of the desired lock range is 50 MHz and the input clock frequency is 50 MHz, the PLL might not maintain lock when the input clock has jitter or the frequency drifts below 50 MHz. You may choose to expand your PLL lock range to ensure your expected input clock frequency is further from the end of the range. For this example, you can enter 45 MHz and 105 MHz to ensure that your target lock range of 50 MHz to 100 MHz is within the PLL lock range.

The Quartus Prime software prompts an error message if it is unable to implement your preferred lock range using this procedure. Therefore, you have to look into other options, such as PLL reconfiguration to support your input frequency range.

### 4.2.2 Programmable Bandwidth with Advanced Parameters

An advanced level of control is also possible for precise control of the PLL loop filter characteristics. This level allows you to explicitly select the following advanced parameters:

- Charge pump current (`charge_pump_current`)
- Loop filter resistance (`loop_filter_r`)
- Loop filter capacitance (`loop_filter_c`)

This option is intended for advanced users who know the exact details of their PLL configuration. You can use this option if you understand the parameters well enough to set them optimally. The files generated are not intended to be reused by the ALTPLL IP core parameter editor. After the ALTPLL IP core output files are specified using the advanced parameters, the Quartus Prime compiler cannot change them. For example, the compiler cannot perform optimization. Thus, your design cannot benefit from improved algorithms of the compiler. The Quartus Prime compiler cannot select better settings or change some settings that the ALTPLL IP core parameter editor finds to be incompatible with your design.

The parameter settings to generate output files using advanced PLL parameters are located on the **Inputs/Lock** page of the ALTPLL IP core parameter editor.

Turn on **Create output file(s) using the 'Advanced' PLL parameters** to enable the feature.

When you turn on this option, the generated output files contain all of the initial counter values used in the PLL. You can use these values for functional simulation in a third-party simulator.





These parameter settings create no additional top-level ports.

#### Related Links

- [Programmable Bandwidth](#) on page 24
- [Charge Pump and Loop Filter](#) on page 43  
Provides more information about the PLL components to update PLL bandwidth in real time.
- [Programmable Bandwidth Parameter Settings](#) on page 53

### 4.2.3 PLL Dynamic Reconfiguration Implementation

To reconfigure the PLL counters, perform the following steps:

1. Assert the `scanclkena` signal at least one `scanclk` cycle prior to shifting in the first bit of `scandata` (`Dn`).
2. Shift the serial data (`scandata`) into the scan chain on the second rising edge of `scanclk`.
3. After all 144 bits have been scanned into the scan chain, deassert the `scanclkena` signal to prevent inadvertent shifting of bits in the scan chain.
4. Assert the `configupdate` signal for one `scanclk` cycle to update the PLL counters with the contents of the scan chain.  
The `scandone` signal goes high indicating that the PLL is being reconfigured. A falling edge indicates that the PLL counters have been updated with new settings.
5. Reset the PLL using the `areset` signal if you make any changes to the `M`, `N`, post-scale output `C` counters, or the `ICP`, `R`, and `C` settings.
6. You can repeat steps 1 through 5 to reconfigure the PLL any number of times.

**Figure 26. PLL Reconfiguration Scan Chain Functional Simulation**

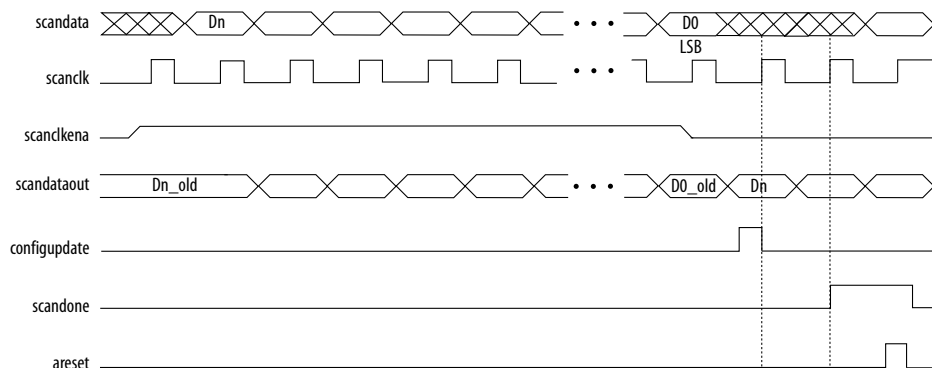

When reconfiguring the counter clock frequency, you cannot reconfigure the corresponding counter phase shift settings using the same interface. You can reconfigure phase shifts in real time using the dynamic phase shift reconfiguration interface. If you wish to keep the same nonzero phase shift setting (for example, 90°) on the clock output, you must reconfigure the phase shift after reconfiguring the counter clock frequency.

#### Related Links

[PLL Reconfiguration](#) on page 31



### 4.2.3.1 Post-Scale Counters (C0 to C4)

You can configure the multiply or divide values and duty cycle of the post-scale counters in real time. Each counter has an 8-bit high time setting and an 8-bit low time setting. The duty cycle is the ratio of output high or low time to the total cycle time, which is the sum of the two.

The post-scale counters have two control bits:

- `rbyypass`—For bypassing the counter
- `rseleodd`—For selecting the output clock duty cycle

When the `rbyypass` bit is set to 1, it bypasses the counter, resulting in a division by one. When this bit is set to 0, the PLL computes the effective division of the VCO output frequency based on the high and low time counters. The PLL implements this duty cycle by transitioning the output clock from high-to-low on the rising edge of the VCO output clock.

For example, if the post-scale divide factor is 10, the high and low count values are set to 5 and 5 respectively, to achieve a 50–50% duty cycle. However, a 4 and 6 setting for the high and low count values, respectively, would produce an output clock with 40–60% duty cycle.

The `rseleodd` bit indicates an odd divide factor for the VCO output frequency with a 50% duty cycle. The PLL implements this duty cycle by transitioning the output clock from high-to-low on a falling edge of the VCO output clock.

For example, if the post-scale divide factor is 3, the high and low time count values are 2 and 1 respectively, to achieve this division. This implies a 67%–33% duty cycle. If you need a 50%–50% duty cycle, you must set the `rseleodd` control bit to 1 to achieve this duty cycle despite an odd division factor. When you set `rseleodd = 1`, subtract 0.5 cycles from the high time and add 0.5 cycles to the low time.

The calculation for the example is shown as follows:

- High time count = 2 cycles
- Low time count = 1 cycle
- `rseleodd = 1` effectively equals:
  - High time count = 1.5 cycles
  - Low time count = 1.5 cycles
  - Duty cycle = (1.5/3)% high time count and (1.5/3)% low time count

#### Related Links

[Programmable Duty Cycle](#) on page 23

### 4.2.3.2 Scan Chain

The MAX 10 PLLs have a 144-bit scan chain.

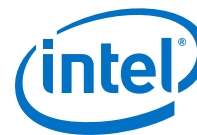

**Table 7. PLL Component Reprogramming Bits**

Block Name	Number of Bits		
	Counter	Control Bit	Total
C4 <sup>6</sup>	16	2 <sup>7</sup>	18
C3	16	2 <sup>7</sup>	18
C2	16	2 <sup>7</sup>	18
C1	16	2 <sup>7</sup>	18
C0	16	2 <sup>7</sup>	18
M	16	2 <sup>7</sup>	18
N	16	2 <sup>7</sup>	18
Charge Pump	9	0	9
Loop Filter <sup>8</sup>	9	0	9
Total number of bits			144

**Figure 27. PLL Component Scan Chain Order**

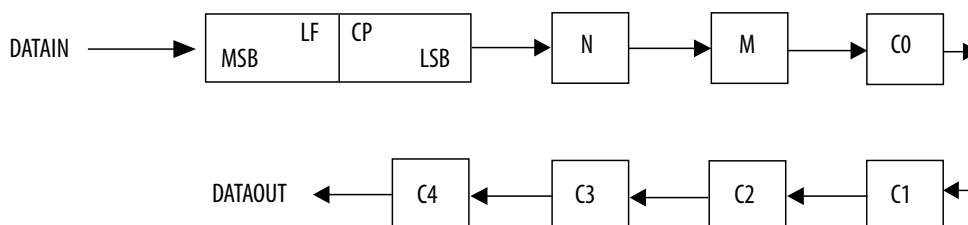

**Figure 28. PLL Post-Scale Counter Scan Chain Bit Order**

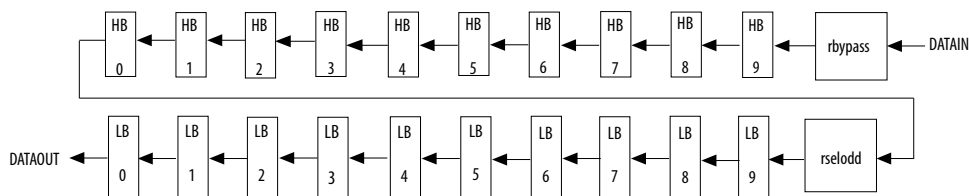

### 4.2.3.3 Charge Pump and Loop Filter

You can reconfigure the following settings to update the PLL bandwidth in real time:

- Charge pump ( $I_{CP}$ )
- Loop filter resistor (R)
- Loop filter capacitor (C)

6 LSB bit for C4 low-count value is the first bit shifted into the scan chain.

7 These two control bits include *rbyypass*, for bypassing the counter, and *rselodd*, for selecting the output clock duty cycle.

8 MSB bit for loop filter is the last bit shifted into the scan chain.

**Table 8. Charge Pump Bit Control**

CP[2]	CP[1]	CP[0]	Setting (Decimal)
0	0	0	0
0	0	1	1
0	1	1	3
1	1	1	7

**Table 9. Loop Filter Resistor Value Control**

LFR[4]	LFR[3]	LFR[2]	LFR[1]	LFR[0]	Setting (Decimal)
0	0	0	0	0	0
0	0	0	1	1	3
0	0	1	0	0	4
0	1	0	0	0	8
1	0	0	0	0	16
1	0	0	1	1	19
1	0	1	0	0	20
1	1	0	0	0	24
1	1	0	1	1	27
1	1	1	0	0	28
1	1	1	1	0	30

**Table 10. Loop Filter High Frequency Capacitor Control**

LFC[1]	LFC[0]	Setting (Decimal)
0	0	0
0	1	1
1	1	3

**Related Links**

- [Programmable Bandwidth](#) on page 24
- [Programmable Bandwidth with Advanced Parameters](#) on page 40
- [Programmable Bandwidth Parameter Settings](#) on page 53

**4.2.3.4 Bypassing PLL Counter**

Bypassing a PLL counter results in a multiplication ( $M$  counter) or a division ( $N$ ,  $C0$  to  $C4$  counters) factor of one.

**Table 11. PLL Counter Settings**

Description	PLL Scan Chain Bits [0..8] Settings								
	LSB								MSB
PLL counter bypassed	X	X	X	X	X	X	X	X	1 <sup>9</sup>
PLL counter not bypassed	X	X	X	X	X	X	X	X	0 <sup>9</sup>

To bypass any of the PLL counters, set the bypass bit to 1. The values on the other bits are ignored.

#### 4.2.4 Dynamic Phase Configuration Implementation

To perform one dynamic phase shift step, perform the following steps:

1. Set PHASEUPDOWN and PHASECOUNTERSELECT as required.
2. Assert PHASESTEP for at least two SCANCLK cycles. Each PHASESTEP pulse allows one phase shift.
3. Deassert PHASESTEP after PHASEDONE goes low.
4. Wait for PHASEDONE to go high.
5. Repeat steps 1 through 4 as many times as required to perform multiple phase shifts.

PHASEUPDOWN and PHASECOUNTERSELECT signals are synchronous to SCANCLK and must meet the  $t_{su}$  and  $t_h$  requirements with respect to the SCANCLK edges.

You can repeat dynamic phase-shifting indefinitely. For example, in a design where the VCO frequency is set to 1,000 MHz and the output clock frequency is set to 100 MHz, performing 40 dynamic phase shifts (each one yields 125 ps phase shift) results in shifting the output clock by 180°, which is a phase shift of 5 ns.

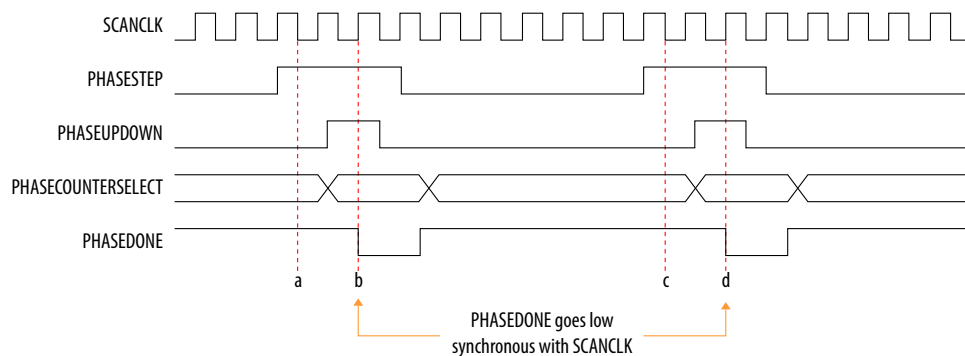
**Figure 29. Dynamic Phase Shift Timing Diagram**

The PHASESTEP signal is latched on the negative edge of SCANCLK (a,c) and must remain asserted for at least two SCANCLK cycles. Deassert PHASESTEP after PHASEDONE goes low.



On the second SCANCLK rising edge (b,d) after PHASESTEP is latched, the values of PHASEUPDOWN and PHASECOUNTERSELECT are latched. The PLL starts dynamic phase-shifting for the specified counters and in the indicated direction.

The PHASEDONE signal is deasserted synchronous to SCANCLK at the second rising edge (b,d) and remains low until the PLL finishes dynamic phase-shifting. Depending on the VCO and SCANCLK frequencies, PHASEDONE low time may be greater than or less than one SCANCLK cycle.

You can perform another dynamic phase-shift after the PHASEDONE signal goes from low to high. Each PHASESTEP pulse enables one phase shift. The PHASESTEP pulses must be at least one SCANCLK cycle apart.

#### Related Links

- [Programmable Phase Shift](#) on page 24
- [Dynamic Phase Configuration Parameter Settings](#) on page 54  
Provides more information about the ALTPLL IP core parameter settings in the Quartus Prime software.
- [ALTPLL\\_RECONFIG Parameters](#) on page 59  
Provides more information about the ALTPLL\_RECONFIG IP core parameter settings in the Quartus Prime software.
- [PLL Dynamic Reconfiguration Parameter Settings](#) on page 54  
Provides more information about the ALTPLL IP core parameter settings in the Quartus Prime software.
- [ALTPLL\\_RECONFIG Parameters](#) on page 59  
Provides more information about the ALTPLL\_RECONFIG IP core parameter settings in the Quartus Prime software.

### 4.2.4.1 Dynamic Phase Configuration Counter Selection

Table 12. Phase Counter Select Mapping

PLL Counter Selection	PHASECOUNTERSELECT [2]	[1]	[0]
All output counters	0	0	0
M counter	0	0	1
C0 counter	0	1	0
C1 counter	0	1	1
C2 counter	1	0	0
C3 counter	1	0	1
C4 counter	1	1	0

#### Related Links

[Programmable Phase Shift](#) on page 24

### 4.2.4.2 Dynamic Phase Configuration with Advanced Parameters

The finest phase shift step resolution you can get in the ALTPLL IP core is 1/8 of the VCO period. If the VCO frequency is at the lower end of the supported VCO range, the phase shift step resolution might be larger than preferred for your design.



You can modify your phase shift resolution using the dynamic phase reconfiguration feature of the PLL. If you want to modify the phase shift resolution without the dynamic phase reconfiguration feature enabled, perform the following steps:

1. Create an ALTPLL instance. Make sure you specify the speed grade of your target device and the PLL type.
2. On the **PLL Reconfiguration** page, turn on **Create optional inputs for dynamic phase reconfiguration** and **Enable phase shift step resolution**.
3. On the **Output Clocks** page, set your desired phase shift for each required output clock. Note all the internal PLL settings shown.
4. On the **Bandwidth/SS** page, click **More Details** to see the internal PLL settings. Note all of the settings shown.
5. On the **Inputs/Lock** page, turn on **Create output file(s) using the 'Advanced' PLL Parameters**.
6. Return to the **PLL Reconfiguration** page and turn off **Create Optional Inputs for Dynamic Phase Reconfiguration**.
7. Click **Finish** to generate the PLL instantiation file(s).

When using Advanced Parameters, the PLL wrapper file (`<ALTPLL_instantiation_name>.v` or `<ALTPLL_instantiation_name>.vhd`) is written in a format that allows you to identify the PLL parameters. The parameters are listed in the **Generic Map** section of the VHDL file, or in the `defparam` section of the Verilog file.

8. Open your PLL instantiation wrapper file and locate either the **Generic Map** or the `defparam` section.
9. Modify the settings to match the settings that you noted in steps 3 and 4.
10. Save the PLL instantiation wrapper file and compile your design.
11. Verify that the output clock frequencies and phases are correct in the PLL Usage report located under the Resource section of the Fitter folder in the Compilation Report.

By using this technique, you can apply valid PLL parameters as provided by the ALTPLL IP core parameter editor to optimize the settings for your design.

Alternatively, you can leave the dynamic phase reconfiguration option enabled and tie the relevant input ports—`phasecounterselct[3..0]`, `phaseupdown`, `phasesstep`, and `scanclk`—to constants, if you prefer not to manually edit the PLL wrapper file using the Advanced PLL Parameters option.

#### Related Links

[Programmable Phase Shift](#) on page 24

## 4.3 ALTPLL\_RECONFIG IP Core

The ALTPLL\_RECONFIG IP core implements reconfiguration logic to facilitate dynamic real-time reconfiguration of PLLs. You can use the IP core to update the output clock frequency, PLL bandwidth, and phase shifts in real time, without reconfiguring the entire FPGA.



Use the ALTPLL\_RECONFIG IP core in designs that must support dynamic changes in the frequency and phase shift of clocks and other frequency signals. The IP core is also useful in prototyping environments because it allows you to sweep PLL output frequencies and dynamically adjust the output clock phase. You can also adjust the clock-to-output ( $t_{CO}$ ) delays in real-time by changing the output clock phase shift. This approach eliminates the need to regenerate a configuration file with the new PLL settings. This operation requires dynamic phase-shifting.

#### Related Links

- [Introduction to Intel FPGA IP Cores](#)  
Provides general information about all Intel FPGA IP cores, including parameterizing, generating, upgrading, and simulating IP cores.
- [Creating Version-Independent IP and Qsys Simulation Scripts](#)  
Create simulation scripts that do not require manual updates for software or IP version upgrades.
- [Project Management Best Practices](#)  
Guidelines for efficient management and portability of your project and IP files.
- [MAX 10 Clocking and PLL User Guide Archives](#) on page 66  
Provides a list of user guides for previous versions of the ALTPLL\_RECONFIG IP core.

### 4.3.1 Obtaining the Resource Utilization Report

For details about the resource usage and performance of the ALTPLL\_RECONFIG IP core, refer to the compilation reports in the Quartus Prime software.

To view the compilation reports for the ALTPLL\_RECONFIG IP core in the Quartus Prime software, follow these steps:

1. On the Processing menu, click **Start Compilation** to run a full compilation.
2. After compiling the design, on the Processing menu, click **Compilation Report**.
3. In the Table of Contents browser, expand the Fitter folder by clicking the "+" icon.
4. Under **Fitter**, expand **Resource section**, and select **Resource Usage Summary** to view the resource usage information.
5. Under **Fitter**, expand **Resource section**, and select **Resource Utilization by Entity** to view the resource utilization information.

### 4.4 Internal Oscillator IP Core

The Internal Oscillator IP core specifies the internal oscillator frequencies for the devices.

#### Related Links

- [Introduction to Intel FPGA IP Cores](#)  
Provides general information about all Intel FPGA IP cores, including parameterizing, generating, upgrading, and simulating IP cores.
- [Creating Version-Independent IP and Qsys Simulation Scripts](#)  
Create simulation scripts that do not require manual updates for software or IP version upgrades.
- [Project Management Best Practices](#)





Guidelines for efficient management and portability of your project and IP files.

- [MAX 10 Clocking and PLL User Guide Archives](#) on page 66  
Provides a list of user guides for previous versions of the Internal Oscillator IP core.



## 5 ALTCLKCTRL IP Core References

### 5.1 ALTCLKCTRL Parameters

**Table 13. ALTCLKCTRL IP Core Parameters for MAX 10 Devices**

This table lists the IP core parameters applicable to MAX 10 devices.

Parameter	Value	Description
<b>How do you want to use the ALTCLKCTRL</b>	<b>For global clock, or For external path</b>	Specify the ALTCLKCTRL buffering mode. You can select from the following modes: <ul style="list-style-type: none"> <li><b>For global clock</b>—Allows a clock signal to reach all parts of the chip with the same amount of skew; you can select input port <code>clkselect</code> to switch between the four clock inputs.</li> <li><b>For external path</b>—Represents the clock path from the outputs of the PLL to the dedicated clock output pins; only one clock output is accepted.</li> </ul>
<b>How many clock inputs would you like?</b>	<b>1, 2, 3, or 4</b>	Specify the number of input clock sources for the clock control block. You can specify up to four clock inputs. You can change the number of clock inputs only if you choose <b>For global clock</b> option.
<b>Create 'ena' port to enable or disable the clock network driven by this buffer</b>	On or Off	Turn on this option if you want to create an active high clock enable signal to enable or disable the clock network.
<b>Ensure glitch-free switchover implementation</b>	On or Off	Turn on this option to implement a glitch-free switchover when you use multiple clock inputs. You must ensure the currently selected clock is running before switching to another source. If the selected clock is not running, the glitch-free switchover implementation will not be able to switch to the new clock source. By default, the <code>clkselect</code> port is set to 00. A clock must be applied to <code>inc1k0x</code> for the values on the <code>clkselect</code> ports to be read.

#### Related Links

- [Global Clock Control Block](#) on page 8
- [Global Clock Network Power Down](#) on page 10
- [Clock Enable Signals](#) on page 11
- [Guideline: Clock Enable Signals](#) on page 33



## 5.2 ALTCLKCTRL Ports and Signals

**Table 14. ALTCLKCTRL Input Ports for MAX 10 Devices**

Port Name	Condition	Description
clkselect[]	Optional	Input that dynamically selects the clock source to drive the clock network that is driven by the clock buffer. Input port [1 DOWNTO 0] wide. If omitted, the default is GND. If this signal is connected, only the global clock network can be driven by this clock control block. The following list shows the signal selection for the binary value: <ul style="list-style-type: none"> <li>• 00—inclk[0]</li> <li>• 01—inclk[1]</li> </ul>
ena	Optional	Clock enable of the clock buffer. If omitted, the default value is V <sub>CC</sub> .
inclk[]	Required	Clock input of the clock buffer. Input port [1 DOWNTO 0] wide. You can specify up to two clock inputs, <code>inclk[1..0]</code> . Clock pins, clock outputs from the PLL, and core signals can drive the <code>inclk[]</code> port. Multiple clock inputs are only supported for the global clock networks.

**Table 15. ALTCLKCTRL Output Ports for MAX 10 Devices**

Port Name	Condition	Description
outclk	Required	Output of the clock buffer.

### Related Links

- [Global Clock Control Block](#) on page 8
- [Global Clock Network Power Down](#) on page 10
- [Clock Enable Signals](#) on page 11
- [Guideline: Clock Enable Signals](#) on page 33

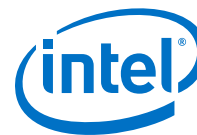

## 6 ALTPLL IP Core References

### 6.1 ALTPLL Parameters

The following tables list the IP core parameters applicable to MAX 10 devices.

#### 6.1.1 Operation Modes Parameter Settings

You can set the operation mode for PLL in the **General/Modes** page of the ALTPLL IP core parameter editor.

**Table 16. Operation Mode Parameter Editor Settings**

Parameter	Value	Description
Which device speed grade will you be using?	Any, 7, or 8	Specify the speed grade if you are not already using a device with the fastest speed. The lower the number, the faster the speed grade.
What is the frequency of the inclock0 input?	—	Specify the frequency of the input clock signal.
Use the feedback path inside the PLL	In normal mode, In source-synchronous compensation mode, In zero-delay buffer mode, or With no compensation	Specify which operation mode to use. For source-synchronous mode and zero-delay buffer mode, you must make PLL Compensation assignments using the Assignment Editor in addition to setting the appropriate mode in the IP core. The assignment allows you to specify an output pin as a compensation target for a PLL in zero-delay buffer mode, or to specify an input pin or group of input pins as compensation targets for a PLL in source-synchronous mode.
Which output clock will be compensated for?	C0, C1, C2, C3, or C4	Specify which PLL output port to compensate. The drop down list contains all output clock ports for the selected device. The correct output clock selection depends on the operation mode that you select. For example, for normal mode, select the core output clock. For zero-delay buffer mode, select the external output clock.

#### Related Links

[Clock Feedback Modes](#) on page 18

#### 6.1.2 PLL Control Signals Parameter Settings

The parameter settings for the control signals are located on the **Inputs/Lock** page of the ALTPLL IP core parameter editor.

Turn on the control signal you want to create from the options available.

#### Related Links

[PLL Control Signals](#) on page 17



### 6.1.3 Programmable Bandwidth Parameter Settings

You can configure the bandwidth of the ALTPLL IP core on the **Bandwidth/SS** page of the ALTPLL IP core parameter editor.

**Table 17. Bandwidth Configuration Parameter Editor Settings**

Parameter	Value	Description
<b>Auto</b>	—	The ALTPLL parameter editor chooses the best possible bandwidth values to achieve the desired PLL settings. In some cases, you can get a bandwidth value outside the <b>Low</b> and <b>High</b> preset range. You can use the programmable bandwidth feature with the clock switchover feature to get the PLL output settings that you desire. You must set the bandwidth to <b>Auto</b> if you want to enable the spread-spectrum feature.
<b>Preset</b>	<b>Low</b>	PLL with a low bandwidth has better jitter rejection but a slower lock time.
	<b>Medium</b>	PLL with a medium bandwidth has a balance between lock time and jitter rejection.
	<b>High</b>	PLL with a high bandwidth has a faster lock time but tracks more jitter.

The table on the right in the **Bandwidth/SS** page shows the values of the following components:

- Charge pump current
- Loop filter resistance
- Loop filter capacitance
- M counter

These parameter settings create no additional top-level ports.

#### Related Links

- [Programmable Bandwidth](#) on page 24
- [Programmable Bandwidth with Advanced Parameters](#) on page 40
- [Charge Pump and Loop Filter](#) on page 43

### 6.1.4 Clock Switchover Parameter Settings

The parameter settings for clock switchover feature are located on the **Clock switchover** page of the ALTPLL IP core parameter editor.

**Table 18. Clock Switchover Parameter Editor Settings**

Parameter	Value	Description
<b>Create an 'inclk1' input for a second input clock</b>	On or Off	Turn on this option to enable the switchover feature. The <code>inclk0</code> signal is by default the primary input clock signal of the ALTPLL IP core.
<b>Create a 'clkswitch' input to manually select between the input clocks</b>	—	Select this option for manual clock switchover mode.
<b>Allow PLL to automatically control the switching between input clocks</b>	—	Select this option for automatic clock switchover mode. The automatic switchover is initiated during loss of lock or when the <code>inclk0</code> signal stops toggling.
<i>continued...</i>		



Parameter	Value	Description
<b>Create a 'clkswitch' input to dynamically control the switching between input clocks</b>	On or Off	Turn on this option for automatic clock switchover with manual override mode. The automatic switchover is initiated during loss of lock or when the <code>clkswitch</code> signal is asserted.
<b>Perform the input clock switchover after (number) input clock cycles</b>	On or Off	Turn on this option to specify the number of clock cycles to wait before the PLL performs the clock switchover. The allowed number of clock cycles to wait is device-dependent.
<b>Create an 'activeclock' output to indicate the input clock being used</b>	On or Off	Turn on this option to monitor which input clock signal is driving the PLL. When the current clock signal is <code>inclk0</code> , the <code>activeclock</code> signal is low. When the current clock signal is <code>inclk1</code> , the <code>activeclock</code> signal is high.
<b>Create a 'clkbad' output for each input clock</b>	On or Off	Turn on this option to monitor when the input clock signal has stopped toggling. The <code>clkbad0</code> signal monitors the <code>inclk0</code> signal. The <code>clkbad1</code> signal monitors the <code>inclk1</code> signal. The <code>clkbad0</code> signal goes high when the <code>inclk0</code> signal stops toggling. The <code>clkbad1</code> signal goes high when the <code>inclk1</code> signal stops toggling. The <code>clkbad</code> signals remain low when the input clock signals are toggling.

**Related Links**

- [Clock Switchover](#) on page 26
- [Guideline: Clock Switchover](#) on page 35

### 6.1.5 PLL Dynamic Reconfiguration Parameter Settings

The parameter settings for the normal dynamic reconfiguration scheme are located on the **PLL Reconfiguration** page of the ALTPLL IP core parameter editor.

**Table 19. PLL Dynamic Reconfiguration Parameter Editor Settings**

Parameter	Value	Description
<b>Create optional inputs for dynamic reconfiguration</b>	On or Off	Turn on this option to enable all the PLL reconfiguration ports for this instantiation— <code>scanclk</code> , <code>scanclkena</code> , <code>scandata</code> , <code>scandone</code> , <code>scandataout</code> , and <code>configupdate</code> .
<b>Initial Configuration File</b>	—	Specify the location of the configuration file that is used to initialize the ALTPLL_RECONFIG IP core.
<b>Additional Configuration File(s)</b>	—	Specify additional configuration file. This file might contain additional settings for the PLL, or might be used to initialize the ALTPLL_RECONFIG IP core.

**Related Links**

- [PLL Reconfiguration](#) on page 31
- [Dynamic Phase Configuration Implementation](#) on page 45

### 6.1.6 Dynamic Phase Configuration Parameter Settings

The parameter settings to enable the dynamic phase configuration feature are located on the **PLL Reconfiguration** page of the ALTPLL IP core parameter editor.



Table 20. Dynamic Phase Configuration Parameter Editor Settings

Parameter	Value	Description
<b>Create optional inputs for dynamic phase reconfiguration</b>	On or Off	Turn on this option to enable the dynamic phase configuration feature. The following ports are created: <ul style="list-style-type: none"> <li>• phasecountersselect[2..0]</li> <li>• phaseupdown</li> <li>• phasestep</li> <li>• scanclk</li> <li>• phasedone</li> </ul>
<b>Enable phase shift step resolution edit</b>	On or Off	Turn on this option to modify the value for <b>Phase shift step resolution(ps)</b> for each individual PLL output clock on the <b>Output Clocks</b> page. By default, the finest phase shift resolution value is 1/8 of the VCO period. If the VCO frequency is at the lower end of the supported VCO range, the phase shift resolution might be larger than preferred for your design. Use this option to fine tune the phase shift step resolution.

#### Related Links

- [Programmable Phase Shift](#) on page 24
- [Dynamic Phase Configuration Implementation](#) on page 45

### 6.1.7 Output Clocks Parameter Settings

The **Output Clocks** page of the ALTPLL parameter editor contains the parameter settings of the clock output signals. You can configure the *c0*, *c1*, *c2*, *c3*, and *c4* clock output signals of the ALTPLL IP core.

Each option has the following two columns:

- Requested settings—The settings that you want to implement.
- Actual settings—The settings closest values that can be implemented in the PLL circuit to best approximate the requested settings.

Use the values in the actual settings column as a guide to adjust the requested settings. If the requested settings for one of the output clocks cannot be approximated, the ALTPLL IP core parameter editor produces a warning message at the top of every page.

Table 21. Output Clocks Parameter Editor Settings

Parameter	Value	Description
<b>Use this clock</b>	On or Off	Turn on this option to generate an output clock port in your ALTPLL instance. The output clock port that is to be compensated for is enabled by default. It cannot be disabled, unless you select a different output clock port to be compensated for.
<b>Enter output clock frequency</b>	—	Specify the frequency of the output clock signal.
<b>Enter output clock parameters</b>	—	Specify the the output clock parameters instead of the frequency.
<b>Clock multiplication factor</b>	—	Specify the clock multiplication factor of the signal.
<i>continued...</i>		



Parameter	Value	Description
<b>Clock division factor</b>	—	Specify the clock division factor of the signal.
<b>Clock phase shift</b>	—	Set the programmable phase shift for an output clock signals. The smallest phase shift is 1/8 of VCO period. For degree increments, the maximum step size is 45 degrees. You can set smaller steps using the <b>Clock multiplication factor</b> and <b>Clock division factor</b> options. For example, if the post-scale counter is 32, the smallest phase shift step is 0.1°. The up and down buttons let you cycle through phase shift values. Alternatively, you can enter a number in the phase shift field manually instead of using the buttons.
<b>Clock duty cycle (%)</b>	—	Set the duty cycle of the output clock signal.
<b>Per Clock Feasibility Indicators</b>	—	Indicate output clocks that contain unachievable settings. The output clock name in red is the name of the clock with unachievable settings. The clock listed in green has no settings issues, and the grayed-out names are the unselected output clocks. You must adjust the requested settings for the affected output clocks to resolve the warning messages.

The ALTPLL IP core parameter editor calculates the simplest fraction, and displays it in the actual settings column. You can use the copy button to copy values from the actual settings to the requested settings.

Figure 30. PLL Output Clock Frequency

$$\text{Output clock frequency} = \text{Input clock frequency} \times \frac{\text{Multiplication factor}}{\text{Division factor}}$$

For example, if the input clock frequency is 100 MHz, and the requested multiplication and division factors are 205 and 1025 respectively, the output clock frequency is calculated as  $100 \times 205/1025=20$  MHz. The actual settings reflect the simplest fraction—the actual multiplication factor is 1, and the actual division factor is 5.

## 6.2 ALTPLL Ports and Signals

Table 22. ALTPLL Input Ports for MAX 10 Devices

Port Name <sup>10</sup>	Condition	Description
areset	Optional	Resets all counters to initial values, including the GATE_LOCK_COUNTER parameter.
clkswitch	Optional	The control input port to dynamically toggle between clock input ports (inclk0 and inclk1 ports), or to manually override the automatic clock switchover. You should create the clkswitch port if only the inclk1 port is created.
configupdate	Optional	Dynamic full PLL reconfiguration.
inclk[ ]	Required	The clock inputs that drive the clock network.

*continued...*

<sup>10</sup> Replace brackets, [], in the port name with integer to get the exact name. For example, inclk0 and inclk1.





Port Name <sup>10</sup>	Condition	Description
		If more than one <code>inclk[ ]</code> port is created, you must use the <code>clkselect</code> port to specify which clock is used. The <code>inclk0</code> port must always be connected; connect other clock inputs if switching is necessary. A dedicated clock pin or PLL output clock can drive this port.
<code>pfdena</code>	Optional	Enables the phase frequency detector (PFD). When the PFD is disabled, the PLL continues to operate regardless of the input clock. Because the PLL output clock frequency does not change for some time, you can use the <code>pfdena</code> port as a shutdown or cleanup function when a reliable input clock is no longer available.
<code>phasecounterselect[ ]</code>	Optional	Specifies counter select. You can use the <code>phasecounterselect[2..0]</code> bits to select either the <code>M</code> or one of the <code>C</code> counters for phase adjustment. One address map to select all <code>C</code> counters. This signal is registered in the PLL on the rising edge of <code>SCANCLK</code> .
<code>phasestep</code>	Optional	Specifies dynamic phase shifting. Logic high enables dynamic phase shifting.
<code>phaseupdown</code>	Optional	Specifies dynamic phase shift direction. 1 = UP, 0 = DOWN. Signal is registered in the PLL on the rising edge of <code>SCANCLK</code> .
<code>scanclk</code>	Optional	Input clock port for the serial scan chain. Free-running clock from core used in combination with <code>PHASESTEP</code> to enable or disable dynamic phase shifting. Shared with <code>SCANCLK</code> for dynamic reconfiguration.
<code>scanckena</code>	Optional	Clock enable port for the serial scan chain.
<code>scandata</code>	Optional	Contains the data for the serial scan chain.

Table 23. ALTPLL Output Ports for MAX 10 Devices

Port Name <sup>11</sup>	Condition	Description
<code>activeclock</code>	Optional	Specifies which clock is the primary reference clock when the clock switchover circuit initiates. If the <code>inclk0</code> is in use, the <code>activeclock</code> port goes low. If the <code>inclk1</code> is in use, the <code>activeclock</code> port goes high. You can set the PLL to automatically initiate the clock switchover when the primary reference clock is not toggling correctly, or you can manually initiate the clock switchover using the <code>clkswitch</code> input port.
<code>c[ ]</code>	Required	The clock output of the PLL.
<code>clkbad[ ]</code>	Optional	<code>clkbad1</code> and <code>clkbad0</code> ports check for input clock toggling. If the <code>inclk0</code> port stops toggling, the <code>clkbad0</code> port goes high. If the <code>inclk1</code> port stops toggling, the <code>clkbad1</code> port goes high.

*continued...*

<sup>10</sup> Replace brackets, `[ ]`, in the port name with integer to get the exact name. For example, `inclk0` and `inclk1`.

<sup>11</sup> Replace the brackets, `[ ]`, in the port name with an integer to get the exact name (for example, `c0` and `c1`).



Port Name <sup>11</sup>	Condition	Description
locked	Optional	<p>This output port acts as an indicator when the PLL has reached phase-locked. The <code>locked</code> port stays high as long as the PLL is locked, and stays low when the PLL is out-of-lock.</p> <p>The number of cycles needed to gate the <code>locked</code> signal is based on the PLL input clock. The gated-lock circuitry is clocked by the PLL input clock. The maximum lock time for the PLL is provided in the <i>MAX 10 Device Datasheet</i>.</p> <p>Take the maximum lock time of the PLL and divide it by the period of the PLL input clock. The result is the number of clock cycles needed to gate the <code>locked</code> signal.</p> <p>The lock signal is an asynchronous output of the PLL. The PLL lock signal is derived from the reference clock and feedback clock feeding the phase frequency detector (PFD) as follows:</p> <ul style="list-style-type: none"> <li>Reference clock = Input Clock/N</li> <li>Feedback clock = VCO/M</li> </ul> <p>The PLL asserts the <code>locked</code> port when the phases and frequencies of the reference clock and feedback clock are the same or within the lock circuit tolerance. When the difference between the two clock signals goes beyond the lock circuit tolerance, the PLL loses lock.</p>
phasedone	Optional	<p>This output port indicates that dynamic phase reconfiguration is completed.</p> <p>When <code>phasedone</code> signal is asserted, it indicates to core logic that the phase adjustment is complete and PLL is ready to act on a possible second adjustment pulse. This signal asserts based on internal PLL timing and deasserts on rising edge of <code>SCANCLK</code>.</p>
scandataout	Optional	<p>The data output for the serial scan chain.</p> <p>You can use the <code>scandataout</code> port to determine when PLL reconfiguration completes. The last output is cleared when reconfiguration completes.</p>
scandone	Optional	<p>This output port indicates that the scan chain write operation is initiated.</p> <p>The <code>scandone</code> port goes high when the scan chain write operation initiates, and goes low when the scan chain write operation completes.</p>

**Related Links**

[PLL Control Signals on page 17](#)

<sup>11</sup> Replace the brackets, [ ], in the port name with an integer to get the exact name (for example, `c0` and `c1`).



## 7 ALTPLL\_RECONFIG IP Core References

### 7.1 ALTPLL\_RECONFIG Parameters

**Table 24. ALTPLL\_RECONFIG IP Core Parameters for MAX 10 Devices**

This table lists the IP core parameters applicable to MAX 10 devices.

Page	Parameter	Value	Description
<b>Parameter Settings</b>	<b>Currently Selected Device Family</b>	—	Specifies the chosen device family.
	<b>Which scan chain type will you be using?</b>	—	The scan chain is a serial shift register chain that is used to store settings. It acts like a cache. When you assert the <i>reconfig</i> signal, the PLL is reconfigured with the values in the cache. The type of scan chain must follow the type of PLL to be reconfigured. The scan chain type has a default value of <b>Top/Bottom</b> .
	<b>Do you want to specify the initial value of the scan chain?</b>	<b>No, leave it blank, Yes, use this file for the content data</b>	Specifies the initial value of the scan chain. Select <b>No, leave it blank</b> to not specify a file or select <b>Yes, use this file for the content data</b> to browse for a <i>.hex</i> or <i>.mif</i> file. The option to initialize from a ROM is not available. However, you can choose to add ports to write to the scan chain from an external ROM during runtime by turning on <b>Add ports to write to the scan chain from external ROM during run time</b> .
	<b>Add ports to write to the scan chain from external ROM during run time</b>	On, Off	Turn on this option to take advantage of cycling multiple configuration files, which are stored in external ROMs during user mode.
<b>EDA</b>	<b>Simulation Libraries</b>	—	Specifies the libraries for functional simulation.
	<b>Generate netlist</b>	On, Off	Turn on this option to generate synthesis area and timing estimation netlist.
<b>Summary</b>	—	—	Specifies the types of files to be generated. A gray checkmark indicates a file that is automatically generated; an unchecked check box indicates an optional file. Choose from the following types of files: <ul style="list-style-type: none"> <li>AHDL Include file (<i>&lt;function name&gt;.inc</i>)</li> <li>VHDL component declaration file (<i>&lt;function name&gt;.cmp</i>)</li> <li>Quartus Prime symbol file (<i>&lt;function name&gt;.bsf</i>)</li> <li>Instantiation template file (<i>&lt;function name&gt;_inst.v</i> or <i>&lt;function name&gt;_inst.vhd</i>)</li> <li>Verilog HDL black box file (<i>&lt;function name&gt;_bb.v</i>)</li> </ul> If the <b>Generate netlist</b> option is turned on, the file for that netlist is also available ( <i>&lt;function name&gt;_syn.v</i> ).

#### Related Links

- [Programmable Phase Shift](#) on page 24



- [Dynamic Phase Configuration Implementation](#) on page 45
- [PLL Reconfiguration](#) on page 31
- [Dynamic Phase Configuration Implementation](#) on page 45

## 7.2 ALTPLL\_RECONFIG Ports and Signals

**Table 25. ALTPLL\_RECONFIG Input Ports for MAX 10 Devices**

Port Name	Condition	Description
clock	Required	Clock input for loading individual parameters. This signal also clocks the PLL during reconfiguration. The clock input port must be connected to a valid clock. Refer to the <i>MAX 10 Device Datasheet</i> for the clock $f_{MAX}$ .
reset	Required	Asynchronous reset input to the IP core. Intel recommends that you reset this IP core before first use to guarantee that it is in a valid state. However, it does power up in the reset state. This port must be connected.
data_in[]	Optional	Data input that provides parameter value when writing parameters. This 9-bit input port provides the data to be written to the scan cache during a write operation. The bit width of the counter parameter to be written determines the number of bits of data_in[] that are read into the cache. For example, the low bit count of the C0 counter is 8-bit wide, so data_in[7..0] is read to the correct cache location. The bypass mode for the C0 counter is 1-bit wide, so data_in[0] is read for the value of this parameter. If omitted, the default value is 0.
counter_type[]	Optional	Specifies the counter type. An input port in the form of a 4-bit bus that selects which counter type should be selected for the corresponding operation (read, write, or reconfig). Refer to the counter_type[3..0] settings table for the mapping between the counter_type value and the physical counter to be set.
counter_param[]	Optional	Specifies the parameter for the value specified in the counter_type port. An input port in the form of a 3-bit bus that selects which parameter for the given counter type should be updated. The mapping to each parameter type and the corresponding parameter bit-width are defined in the counter_param[3..0] settings table.
read_param	Optional	Reads the parameter specified with the counter_type and counter_param ports from cache and fed to the data_out[] port. When asserted, the read_param signal indicates that the scan cache should be read and fed to data_out[]. The bit location of the scan cache and the number of bits read and sent to data_out[] depend on the counter_type and counter_param values. The read_param signal is sampled at the rising clock edge. If the read_param signal is asserted, the parameter value is read from the cache. Assert the read_param signal for 1 clock cycle only to prevent the parameter from being read twice. The busy signal is asserted on the rising clock edge following the assertion of the read_param signal. While the parameter is read, the busy signal remains asserted. After the busy signal is deasserted, the value on data_out[] is valid and the next parameter can be loaded. While the busy signal is asserted, the value on data_out[] is not valid. When the read_param signal is asserted, the busy signal is only asserted on the following rising edge of the clock and not on the same clock cycle as the read_param signal.

*continued...*



Port Name	Condition	Description
write_param	Optional	<p>Writes the parameter specified with the counter_type and counter_param ports to the cache with the value specified on the data_in[] port.</p> <p>When asserted, the write_param signal indicates that the value on data_in[] should be written to the parameter specified by counter_type[] and counter_param[]. The number of bits read from the data_in[] port depends on the parameter. The write_param signal is sampled at the rising clock edge. If the write_param signal is asserted, the parameter value is written to the cache. Assert the write_param signal for 1 clock cycle only to prevent the parameter from being written twice.</p> <p>The busy signal is asserted on the rising clock edge following the assertion of the write_param signal. While the parameter is being written, the busy signal remains asserted and input to data_in[] is ignored. After the busy signal is deasserted, the next parameter can be written.</p> <p>When the write_param signal is asserted, the busy signal is only asserted on the following rising edge of the clock. The busy signal is not asserted on the same clock cycle as the write_param signal.</p>
reconfig	Required	<p>Specifies that the PLL should be reconfigured with the PLL settings specified in the current cache.</p> <p>When asserted, the reconfig signal indicates that the PLL should be reconfigured with the values in the cache. The reconfig signal is sampled at the rising clock edge. If the reconfig signal is asserted, the cached settings are loaded in the PLL. Assert the reconfig signal for 1 clock cycle only to prevent reloading the PLL configuration. The busy signal is asserted on the rising clock edge following the assertion of the reconfig signal. While the PLL is being loaded, the busy signal remains asserted. After the busy signal is deasserted, the parameter values can be modified again.</p> <p>During and after reconfiguration, the scan chain data cache remains unchanged. This allows you to easily create a new set of reconfiguration settings using only one parameter.</p> <p>If write_param has not been asserted since the previous assertion of reconfig, the entire scan chain is shifted in to the PLL again.</p> <p>When the reconfig signal is asserted, the busy signal is only asserted on the following rising edge of the clock. The busy signal is not asserted on the same clock cycle as the reconfig signal.</p>
pll_areset_in	Optional	<p>Input signal indicating that the PLL should be reset.</p> <p>When asserted, the pll_areset_in signal indicates the PLL IP core should be reset. This port defaults to 0 if left unconnected. When using the ALTPLL_RECONFIG IP core in a design, you cannot reset the PLL in any other way. You must use this IP core port to manually reset the PLL.</p>
pll_scandone	Optional	<p>Input port for the ALTPLL_RECONFIG IP core. This port is driven by the PLL's scandone output signal and determines when the PLL is reconfigured.</p>
pll_scandataout	Required	<p>Input port driven by the scandataout signal from the ALTPLL IP core. Use this port to read the current configuration of the ALTPLL IP core. This input port holds the ALTPLL scan data output from the dynamically reconfigurable bits. The pll_scandataout port must be connected to the scandataout port of the PLL. The activity on this port can only be observed when the reconfig signal is asserted.</p>

**Table 26. ALTPLL\_RECONFIG Output Ports for MAX 10 Devices**

Port Name	Condition	Description
data_out[]	Optional	Data read from the cache when read_param is asserted.
<i>continued...</i>		



Port Name	Condition	Description
		This 9-bit output bus provides the parameter data to the user. When the <code>read_param</code> signal is asserted, the values on <code>counter_type[]</code> and <code>counter_param[]</code> determine the parameter value that is loaded from cache and driven on the <code>data_out[]</code> bus. When the IP core deasserts the <code>busy</code> signal, the appropriate bits of the bus (for example, [0] or [3..0]) hold a valid value.
<code>busy</code>	Optional	Indicates that the PLL is reading or writing a parameter to the cache, or is configuring the PLL. While the <code>busy</code> signal is asserted, no parameters can be read or written, and no reconfiguration can be initiated. Changes to the IP core can be made only when the <code>busy</code> signal is not asserted. The signal goes high when the <code>read_param</code> , <code>write_param</code> , or <code>reconfig</code> input port is asserted, and remains high until the specified operation is complete. In the case of a reconfiguration operation, the <code>busy</code> signal remains high until the <code>pll_areset</code> signal is asserted and then deasserted.
<code>pll_areset</code>	Required	Drives the <code>areset</code> port on the PLL to be reconfigured. The <code>pll_areset</code> port must be connected to the <code>areset</code> port of the ALTPLL IP core for the reconfiguration to function correctly. This signal is active high. The <code>pll_areset</code> is asserted when <code>pll_areset_in</code> is asserted, or, after reconfiguration, at the next rising clock edge after the <code>scandone</code> signal goes high. If you use the ALTPLL_RECONFIG IP core, use the <code>pll_areset</code> output port to drive the PLL <code>areset</code> port.
<code>pll_configupdate</code>	Optional	Drives the <code>configupdate</code> port on the PLL to be reconfigured. When asserted, the <code>pll_configupdate</code> port loads selected data to PLL configuration latches. The signal is asserted after the final data bit is sent out.
<code>pll_scanclk</code>	Required	Drives the <code>scanclk</code> port on the PLL to be reconfigured. For information about the maximum <code>scanclk</code> frequency for the various devices, refer to the respective device handbook.
<code>pll_scanclkena</code>	Optional	This port acts as a clock enable for the <code>scanclk</code> port on the PLL to be reconfigured. Reconfiguration begins on the first rising edge of <code>pll_scanclk</code> after <code>pll_scanclkena</code> assertion. On the first falling edge of <code>pll_scanclk</code> , after the deassertion of the <code>pll_scanclkena</code> signal, the IP core stops scanning data to the PLL.
<code>pll_scandata</code>	Required	Drives the <code>scandata</code> port on the PLL to be reconfigured. This output port from the IP core holds the scan data input to the PLL for the dynamically reconfigurable bits. The <code>pll_scandata</code> port sends <code>scandata</code> to the PLL. Any activity on this port can only be observed when the <code>reconfig</code> signal is asserted.

### 7.3 ALTPLL\_RECONFIG Counter Settings

Table 27. `counter_type[3..0]` Settings for MAX 10 Devices

Counter Selection	Binary	Decimal
N	0000	0
M	0001	1
CP/LF	0010	2
VCO	0011	3
C0	0100	4
<i>continued...</i>		



Counter Selection	Binary	Decimal
C1	0101	5
C2	0110	6
C3	0111	7
C4	1000	8
Illegal value	1001	9
Illegal value	1010	10
Illegal value	1011	11
Illegal value	1100	12
Illegal value	1101	13
Illegal value	1110	14
Illegal value	1111	15

**Table 28.** counter\_param[2..0] Settings for MAX 10 Devices

Counter Type	Counter Param	Binary	Decimal	Width (bits)
Regular counters (C0 - C4)	High count	000	0	8
	Low count	001	1	8
	Bypass	100	4	1
	Mode (odd/even division)	101	5	1
CP/LF	Charge pump unused	101	5	5
	Charge pump current	000	0	3
	Loop filter unused	100	4	1
	Loop filter resistor	001	1	5
	Loop filter capacitance	010	2	2
VCO	VCO post scale	000	0	1
M/N counters	High count	000	0	8
	Low count	001	1	8
	Bypass	100	4	1
	Mode (odd/even division)	101	5	1
	Nominal count	111	7	9

For even nominal count, the counter bits are automatically set as follows:

- $high\_count = Nominalcount/2$
- $low\_count = Nominalcount/2$

For odd nominal count, the counter bits are automatically set as follows:

- $high\_count = (Nominalcount + 1)/2$
- $low\_count = Nominalcount - high\_count$
- odd/even division bit = 1

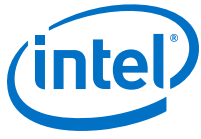

For nominal count = 1, bypass bit = 1.





## 8 Internal Oscillator IP Core References

---

### 8.1 Internal Oscillator Parameters

**Table 29. Internal Oscillator IP Core Parameters for MAX 10 Devices**

This table lists the IP core parameters applicable to MAX 10 devices.

Parameter	Value	Description
<b>Clock Frequency</b>	55, 116	Specify the clock frequency for simulation. If not specified, the default value is 55 MHz.

### 8.2 Internal Oscillator Ports and Signals

**Table 30. Internal Oscillator Input Port for MAX 10 Devices**

Port Name	Condition	Description
oscena	Required	Input control signal to turn on or turn off the internal oscillator.

**Table 31. Internal Oscillator Output Port for MAX 10 Devices**

Port Name	Condition	Description
clkout	Optional	Output clock from the internal oscillator.



## A MAX 10 Clocking and PLL User Guide Archives

---

If an IP core version is not listed, the user guide for the previous IP core version applies.

IP Core Version	User Guide
15.1	<a href="#">MAX 10 Clocking and PLL User Guide</a>
15.0	<a href="#">MAX 10 Clocking and PLL User Guide</a>
14.1	<a href="#">MAX 10 Clocking and PLL User Guide</a>

---

Intel Corporation. All rights reserved. Intel, the Intel logo, Altera, Arria, Cyclone, Enpirion, MAX, Nios, Quartus and Stratix words and logos are trademarks of Intel Corporation or its subsidiaries in the U.S. and/or other countries. Intel warrants performance of its FPGA and semiconductor products to current specifications in accordance with Intel's standard warranty, but reserves the right to make changes to any products and services at any time without notice. Intel assumes no responsibility or liability arising out of the application or use of any information, product, or service described herein except as expressly agreed to in writing by Intel. Intel customers are advised to obtain the latest version of device specifications before relying on any published information and before placing orders for products or services.

\*Other names and brands may be claimed as the property of others.

ISO  
9001:2008  
Registered



## B Document Revision History for MAX 10 Clocking and PLL User Guide

Date	Version	Changes
February 2017	2017.02.21	Rebranded as Intel.
November 2015	2015.11.02	<ul style="list-style-type: none"> <li>Removed the topics about the IP catalog and parameter editor, generating IP cores, and the files generated by the IP core, and added a link to <i>Introduction to Altera IP Cores</i>.</li> <li>Changed instances of <i>Quartus II</i> to <i>Quartus Prime</i>.</li> </ul>
June 2015	2015.06.12	Added connectivity restriction guideline to the PLL design considerations.
May 2015	2015.05.04	Rearranged the fine resolution phase shift equation.
December 2014	2014.12.15	<ul style="list-style-type: none"> <li>Corrected the statement that if you do not use the dedicated clock input pins for clock input, you can also use them as general-purpose input or output pins.</li> <li>Added description in Internal Oscillator Architecture and Features to state that the internal ring oscillator operates up to 232 MHz and this frequency is not accessible.</li> <li>Added connectivity restrictions guideline for internal oscillator.</li> <li>Added Internal Oscillator IP Core parameter: Clock Frequency.</li> <li>Moved Internal Oscillator Frequencies table from Internal Oscillator Architecture and Features chapter to MAX 10 FPGA Device Datasheet.</li> </ul>
September 2014	2014.09.22	Initial release.

Intel Corporation. All rights reserved. Intel, the Intel logo, Altera, Arria, Cyclone, Enpirion, MAX, Nios, Quartus and Stratix words and logos are trademarks of Intel Corporation or its subsidiaries in the U.S. and/or other countries. Intel warrants performance of its FPGA and semiconductor products to current specifications in accordance with Intel's standard warranty, but reserves the right to make changes to any products and services at any time without notice. Intel assumes no responsibility or liability arising out of the application or use of any information, product, or service described herein except as expressly agreed to in writing by Intel. Intel customers are advised to obtain the latest version of device specifications before relying on any published information and before placing orders for products or services.

\*Other names and brands may be claimed as the property of others.

ISO  
9001:2008  
Registered